

**TECHNICAL CLOTHING GROUP**

**TCG**

**RECOMMENDATIONS CONCERNING CHARACTERISTICS  
AND FAULTS IN FABRICS TO BE USED  
FOR CLOTHING**

**PROPOSAL MARCH 2006**

## TABLE OF CONTENTS.

|  | <b>Page</b> |
|--|-------------|
| <b>Title.</b>  | 1           |
| <b>Table of contents.</b>  | 2-5         |
| <b>I. Aim of recommendations.</b>  | 6           |
| Addresses of National Organizations  | 6-12        |
| <b>II. General.</b>  | 13          |
| 2.1 Limits and field of application.   | 13          |
| 2.2 Method of Testing.   | 14          |
| 2.3 Tolerances.  | 14          |
| 2.4 Arbitration.   | 14          |
| <br>   |             |
| <b>PART 1.</b>   | 15          |
| CONTENTS OF THIS PART  | 15          |
| <br>   |             |
| <b>III. Definitions, methods of measurement and of checking and tolerances.</b>                            | 16-32       |
| <br>   |             |
| Category A.  | 16          |
| A1 Warpway (full or part length): thick or thin end,<br>tight or slack end, missing end, double end.       | 16          |
| A2 Stripes in the warp.  | 16          |
| A3 Weftway thick or thin pick, tight or slack pick,<br>missing pick, broken pick, double pick and trailer. | 17          |
| A4 Bars in the weft.   | 18          |
| A5 Knots or slubs in warps or weft threads.  | 18          |
| A6 Faulty mending and burling, tears, holes and stains.  | 19          |
| A7 Pieces cut in several parts ("throughs").   | 19          |
| <br>   |             |
| Category B.  | 20          |
| B1 Design.   | 20          |
| B2 Mass per square metre (weight per square metre).  | 21          |
| B3 Length of the piece.  | 22          |
| B4 Length of an order.   | 22          |
| B5 Width.  | 23          |
| B6 Irregularity of checks along the piece.   | 23          |
| B7 Skew.   | 24          |
| B8 Bowing in the warp.   | 25          |
| B9 Relaxation shrinkage of non washable fabrics after steam<br>pressing.                                   | 25          |

|   |       |
|---|-------|
| Category C.   | 27    |
| C1 Variation in shade compared with the sample, within the piece and from piece to piece. | 27    |
| C2 Difference in tension warpway between the body of the cloth and the selvages.          | 27    |
| C3 Bowing of the weft.  | 28    |
| C4 Non-symmetrical distribution of design.  | 28    |
| C5 Make-up of the piece.  | 29    |
| C6 Finish.  | 30    |
| C7 Disagreeable odour.  | 30    |
| C8 Creases.   | 31    |
| C9 Foreign matter.  | 31    |
| Appendix 1 Concerning C1 Variation of shade along the piece (method of testing).          | 32    |
| <b>PART 2.</b>  | 33    |
| CONTENTS OF THIS PART   | 33    |
| <b>IV. Characteristics (definitions, test methods, quality standards and tolerances).</b> | 34-60 |
| 1 Colour fastness to light.   | 34    |
| 2 Colour fastness to artificial weathering  | 35    |
| 3 Colour fastness to perspiration.  | 36    |
| 4 Colour fastness to dry cleaning using perchloroethylene.                                | 37    |
| 5 Colour fastness to washing.   | 38    |
| 6 Colour fastness to rubbing.   | 39    |
| 7 Colour fastness to pressing or ironing.   | 40    |
| 8 Colour fastness to spotting: water.   | 41    |
| 9 Colour fastness to rubbing: organic solvents.   | 42    |
| 10 Composition.   | 43    |
| 11 Number of ends and picks.  | 44    |
| 12 Weave.   | 45    |
| 13 Breaking strength and elongation.  | 46    |
| 14 Breaking strength (grab method).   | 47    |
| 15 Tear strength.   | 48    |
| 16 Seam slippage: Method 1.   | 49    |
| 17 Seam slippage: Method 2.   | 50    |
| 18 Resistance to abrasion.  | 51    |
| 19 Resistance to pilling.   | 52    |
| 20 Resistance to snagging.  | 53    |
| 21 Dimension stability to washing.  | 54    |
| 22 Dimension stability to dry cleaning.   | 55    |
| 23 Crease recovery.   | 56    |
| 24 Water-repellency   | 57    |
| 25 Water-proofness  | 58    |
| 26 Air permeability   | 59    |
| 27 Resistance to hydrolysis   | 60    |

|  |  |       |
|--|--|-------|
| <b>PART 3.</b>                                     |  | 61    |
| <b>CONTENTS OF THIS PART</b>                       |  | 61    |
| <b>V. Product information and recommendations.</b> |  | 62-75 |
| Section 1  | Characteristics concerning the woven material.         | 63    |
| Section 1  | Characteristics concerning the knitted material.       | 64    |
| Section 2  | Characteristics concerning the fabric and the garment: |       |
| 2.1  | Trousers and shorts.                                   | 65    |
| 2.2  | Skirts.  | 66    |
| 2.3  | Jackets.   | 67    |
| 2.4  | Coats.   | 68    |
| 2.5  | Knitwear.  | 69    |
| 2.6  | Anoraks, skiwear and sportswear.                       | 70    |
| 2.7  | Pyjamas and nightwear.                                 | 71    |
| 2.8  | Shirts, dresses and blouses.                           | 72    |
| 2.9  | Lingerie.  | 73    |
| 2.10   | Swimwear.  | 74    |
| 2.11   | Lining.  | 75    |

**VI Short explanation of the test methods** 76-86

CONTENTS OF THIS PART 76

|     |                   |  |    |
|-----|-------------------|--|----|
| 1.  | ISO 5077 & 6330   | Dimensional stability to machine washing and tumble drying.    | 77 |
| 2.  | ISO 3175          | Dimensional stability to commercial dry-cleaning.              | 77 |
| 3.  | ISO 13938-2       | Bursting strength, bursting distension.                        | 77 |
| 4.  | ISO 13934-1       | Tensile strength – strip.                                      | 78 |
| 5.  | ISO 13934-2       | Tensile strength – grab.                                       | 78 |
| 6.  | ISO 13937-1       | Tear strength.   | 78 |
| 7.  | EN 13936-1        | Seam slippage: Fixed seam opening method.                      | 79 |
| 8.  | EN 13936-2        | Seam slippage: Fixed load method                               | 79 |
| 9   | EN 12947-2        | Abrasion resistance.   | 80 |
| 10. | EN 2313           | Crease tendency / angle of recovery.                           | 80 |
| 11. | ISO 9867          | Crease tendency / wrinkle recovery.                            | 81 |
| 12. | EN-ISO 12945-2    | Resistance to pilling.   | 81 |
| 13. | ASTM D 3939-93    | Resistance to snagging.  | 81 |
| 14. | ISO 105 C06/08/09 | Colour fastness to washing.                                    | 82 |
| 15. | ISO 105 D01       | Colour fastness to dry cleaning.                               | 82 |
|     | ISO 105 D02       | Colour fastness to rubbing organic solvents.                   | 82 |
| 16. | ISO 105 X11       | Colour fastness to hot pressing-ironing                        | 83 |
| 17. | ISO 105 B02/04    | Colour fastness to artificial light and artificial weathering. | 83 |
| 18. | ISO 105 X12       | Colour fastness to rubbing.                                    | 84 |
| 19. | ISO 105 E01       | Colour fastness to water.                                      | 84 |
|     | ISO 105 E02       | Colour fastness to sea water.                                  | 84 |
|     | ISO 105 E04       | Colour fastness to perspiration.                               | 84 |
| 20. | ISO 105 E07       | Colour fastness to spotting water.                             | 84 |
| 21. | ISO 105 E03       | Colour fastness to chlorinated water.                          | 85 |
| 22. | ISO 3758          | Care labelling codes using symbols.                            | 85 |
| 23. | ISO 4920          | Water-repellency   | 85 |
| 24. | ISO 811 + EN 343  | Water-proofness  | 86 |
| 25. | EN-ISO 9237       | Air permeability   | 86 |
| 26. | EN 12447          | Resistance to hydrolysis                                       | 86 |

## I. AIM OF RECOMMENDATIONS

The aim of these Recommendations, which are the revision of those approved by the Association Européenne des Industries de l'Habillement (A.E.I.H.) in 1983 is to standardise practise between fabric suppliers and clothing manufacturers as regards characteristics and faults in fabrics to be used in clothing.

Standardisation in this field is necessary when taking account of the technological advances in clothing and fabric production.

The text of the Recommendations should be brought to the notice of suppliers before the contracts are established. The English text will be the reference for the interpretation of any of the terms used.

These Recommendations may be revised in the light of experience.

Request for additional information or subsequent suggestions should be sent to:  
The National Organisation in:

Austria:

Fachverband der Bekleidungsindustrie Österreichs - FBO  
Wiedner Hauptstrasse 63  
A - 1045 Wien - Autriche  
Tél.: 00/43/5/90.900.4903  
Fax : 00/43/5/90.900.4908  
E-mail: office@fashion-industry.at  
Internet: <http://www.fashion-industry.at>

Belgium:

CREAMODA – Belgium Fashion  
Leliegarde 22  
B - 1731 Zellik – Belgique  
Tél.: 02/238.10.11  
Fax.: 02/238.10.10  
E-mail.: info@creamoda.be  
Internet.: <http://www.creamoda.be>

Czech Republic:

Association of Textile, Clothing and Leather Industry  
Asociace Textilního Odevního Kožedělného průmyslu - ATOK  
Těšnov 5  
CZ – 110 01 Praha 1 - Czech Republic  
Tél.: 00/420/224/805.341  
Fax.: 00/420/224/805.339  
E-mail.: atok@atok.cz  
Internet.: <http://www.atok.cz>

Denmark:  
Federation of Danish Textile and Clothing  
Birk Centerpark 38 - P.O. Box 507  
DK - 7400 Herning - Denmark  
Tél.: 00/45/97/117.200  
Fax : 00/45/97/117.215  
E-mail: [info@textile.dk](mailto:info@textile.dk)  
Internet: <http://www.textile.dk>

Estonia:  
Estonian Clothing and Textile Association - ECTA  
Tartu mtn 63 -  
EE - 10115 Tallinn - Estonia  
Tél.: 00/372/6/115.567  
Fax : 00/372/6/115.568  
E-mail: [info@textile.ee](mailto:info@textile.ee)  
Internet: <http://www.textile.ee>

Finland:  
Tekstiili -ja vaateusteollisuus ry  
Eteläranta 10 -  
FIN - 00130 Helsinki - Finlande  
Tél.: 00/358/9/686.121  
Fax : 00/358/9/653.305  
E-mail: [veli-matti.kankaanpaa@finatex.fi](mailto:veli-matti.kankaanpaa@finatex.fi)  
Internet: <http://www.finatex.fi>

France:  
Union Française des Industries de l'Habillement - UFIH  
8 rue Montesquieu  
F - 75001 Paris - France  
Tél.: 00/33/1/4455.6660  
Fax: 00/33/1/4455.6666  
E-mail: [secretariatufih@lamodefrancaise.org](mailto:secretariatufih@lamodefrancaise.org)  
Internet: <http://www.lamodefrancaise.org>

Germany:  
Gesamtverband der deutschen Textil- und Modeindustrie - GTMI  
Frankfurter Strasse 10-14 - Postfach 53 40  
D - 65728 Eschborn - Deutschland  
Tél.: 00/49/6196/9660  
Fax : 00/49/6196/42170  
E-mail: [info@textil-mode.de](mailto:info@textil-mode.de)  
Internet: <http://www.textile-mode.de>  
Brussels Office :  
rue de l'Amazone 2  
B – 1050 Bruxelles  
Tél.: 02/535.72.58  
Fax.: 02/534.96.96  
E-mail.: [EU-Office@textil-mode.de](mailto:EU-Office@textil-mode.de)

German Fashion  
An Lyskirchen 14  
D – 50676 Köln – Deutschland  
Tel 00/49/221 77 44 131  
Fax 00/49/221 77 44 137  
E – mail: [info@germanfashion.net](mailto:info@germanfashion.net)  
Internet: <http://www.germanfashion.de>

Dialog Textil – Bekleidung  
Am Werbering 5  
D – 85551 Heimstetten  
Tel 00/49/89 43606600  
Fax 00/49/89 43606603  
E – mail: [info@dialog-dtb.de](mailto:info@dialog-dtb.de)  
Internet: <http://www.dialog-dtb.de>

Greece:  
Hellenic Clothing Industry Association - HCIA  
51 Ermou st. – 3<sup>rd</sup> Floor  
GR – 10563 Athens - Greece  
Tél.: 00/30/210/32.23.979  
Fax.: 00/30/210/32.39.159  
E-mail : [info@skee.gr](mailto:info@skee.gr)  
SEPEE  
18a Ermou st.  
GR – 54624 Thessaloniki  
Tél.: 00/30/2310/257.075  
Fax.: 00/30/2310/257.076  
E-mail: [info@greekfashion.gr](mailto:info@greekfashion.gr)  
Internet: <http://www.greekfashion.gr>  
Athens Office :  
51 Ermou st. – 3<sup>rd</sup> Floor  
GR – 10563 Athens  
Tél.: 00/30/210/32.23.811  
Fax.: 00/30/210/32.39.159  
E-mail : [info@skee.gr](mailto:info@skee.gr)

Hungary:  
Association of Hungarian Light Industry - AHLI  
Jozsef krt. 29  
H - 1085 Budapest - Hungary  
Tél.: 00/36/1/2660694  
Fax: 00/36/1/2661625  
E-mail: [mksz2@axelero.hu](mailto:mksz2@axelero.hu)  
Internet:



Ireland:

Irish Clothing & Textiles Alliance - ICATA  
Confederation House - 84/86 Lower Baggot Street  
IE - Dublin 2 - Ireland  
Tél.: 00/353/1/605.1529 – 605.1560  
Fax : 00/353/1/638.1529 – 638.1560  
E-mail: susan.doyle@ibec.ie  
Internet: <http://www.ibec.ie/icata>

Italy:

Sistema Moda Italia - SMI  
Viale Sarca N.223 -  
I - 20126 Milano - Italie  
Tél.: 00/39/02/6411.91  
Fax : 00/39/02/6610.3667-70  
E-mail: costa@sistemamodaitalia.it  
Internet: <http://www.sistemamodaitalia.it>

Latvia:

Lithuanian Apparel and Textile Industry Association - LATIA  
Lietuvos aprangos ir tekstilės imonių asociacija  
Saltoniskiu 29/3  
Lithuania - 2677 Vilnius  
Tél.: 00/370/5/2790.131  
Fax: 00/370/5/2721.127  
E-mail: latia@latia.lt  
Internet: <http://www.latia.lt>

Netherlands:

MODINT - Ondernemersorganisatie voor mode, interieur en textiel  
Postbus 428  
NL – 3700 AK Zeist - Pays Bas  
Tél.: 00/31/30/2320900  
Fax: 00/31/30/2320999  
Internet: <http://www.modint.nl>  
E-mail: info@modint.nl

Norway:

Association of Textile, Footwear and Sporting Goods - TBL Teko  
Oscars gate 20 - Postboks 7072 Majorstua  
N - 0306 Oslo - Norvège  
Tél.: 00/47/22/59.00.00  
Fax : 00/47/22/59.00.06  
E-mail: kr@tbl.no  
Internet.: <http://www.tbl.no>

Poland:  
Polish Federation of Apparel & Textiles  
Ul. Kielecka 7,  
Poland - 81-303 Gdynia  
Tél.: 00/48/58/620.9501  
Fax: 00/48/58/621.6923  
E-mail: [piot.gdynia@textiles.pl](mailto:piot.gdynia@textiles.pl)  
Internet : <http://www.textiles.pl>

Portugal:  
ANIVÉC/APIV Associação Nacional das Indústrias de Vestuário e Confecção  
National Association of Clothing Manufacturers  
Av. da Boavista, 3523-7°  
P – 4100-139 Porto - Portugal  
Tél.: +351 226165470  
Fax: +351/226100049 / +351 226168714  
E-mail: [tecnico@anivec.com](mailto:tecnico@anivec.com)  
Internet: <http://www.anivec.com>

Slovakia:  
Textile and Clothing Association of the Slovak Republic  
Asociacia textilneho a odevneho priemyslu SR - ATOP  
Stefanikova 19  
SR - 911 60 Trencin - Slovak Republic  
Tél.: 00/421/32/7437.811  
Fax : 00/421/32/7431.440  
E-mail: [atop@atop.sk](mailto:atop@atop.sk)  
Internet: <http://www.atop.sk>

Slovenia:  
Gospodarska Zbornica Slovenije  
Chamber of Commerce and Industry of Slovenia, Textiles,  
Clothing and Leather Processing Association  
Dimiceva 13  
SI - 1504 Ljubljana - Slovenia  
Tél.: 00/386/1/5898.286  
Fax.: 00/386/1/5898.100-5898.200  
E-mail: [jadranka.marasovic@gzs.si](mailto:jadranka.marasovic@gzs.si)  
Internet: <http://www.gzs.si>

Spain:

Consejo Intertextil Español - CIE

Granvia 670 -

ES - 08010 Barcelona – Espagne

Tél.: 00/34/93/318.9200

Fax : 00/34/93/302.6235

E-mail: [intertextil@aitpa.es](mailto:intertextil@aitpa.es)

Internet.: <http://www.consejointertextil.com>

Sweden:

TEKOindustrierna

P.O. - Box 5510

S - 11485 Stockholm - Suède

Tél.: 00/46/8/762.66.62

Fax : 00/46/8/762.68.87

E-mail: [teko@teko.se](mailto:teko@teko.se)

Internet: <http://www.teko.se>

Switzerland:

Gesamtverband der Schweizerischen Textil- und Bekleidungsindustrie

Beethovenstrasse 20 - Postfach 2900

CH - 8022 Zürich - Suisse

Tél.: 00/41/44/289.79.00

Fax : 00/41/44/289.79.81

E-mail: [contact@tvs.ch](mailto:contact@tvs.ch)

Internet: <http://www.swisstextiles.ch>

Turkey:

Turkish Clothing Manufacturers' Association & Turkish Clothing Exporters' Association

Mehmet Akif Cad., 1. Sok.,

Akin Is Merkezi - 2 NO: 23 Kat: 5 D:19 Sirinevler

Turkey - 34510 Istanbul

Tél.: 00/90/212/639.76.56

Fax: 00/90/212/451.61.13 - 00/90/212/451.61.03

E-mail: [tgsd@tgsd.org](mailto:tgsd@tgsd.org)

Internet: <http://www.tgsd.org>

TUTSIS - Türkiye Tekstil Sanayii Isverenleri Sendikası

Turkish Textile Employers' Association

Visnezade Cami Meydani Sok. Efe Apt.

6/10

Turkey - 80680 Istanbul

Tél.: 00/90/212/260.1405-09

Fax: 00/90/212/258.2974 - 00/90/212/227.4003

E-mail: [info@tekstilisveren.org.tr](mailto:info@tekstilisveren.org.tr)

Internet: <http://www.tekstilisveren.org.tr>

ITKIB

Turkish Textile and Apparel Exporters' Association

Coban çeşme mevkindi

Sanayi cad.

Disticaret kompleksi B/blok

Turkey – Yeni bosna – 34 520 Istanbul

Tél.: 00/90/212/454.02.00

Fax.: 00/90/212/454.04.09

E-mail: [info@itkib.org.tr](mailto:info@itkib.org.tr)

Internet: <http://www.itkib.org.tr>

Brussels Office :

rue de la Loi 28 – Bte 17

B – 1040 Bruxelles

Tél.: 02/285.43.30

Fax: 02/285.43.38

E-mail: [itkib.bxl@skynet.be](mailto:itkib.bxl@skynet.be)

United Kingdom:

Textile Forum

5 Portland Place -

GB - London W1B 1PW - United Kingdom

Tél.: 00/44/20/7636.77.88

Fax : 00/44/20/7636.75.15

E-mail: [batc@dial.pipex.com](mailto:batc@dial.pipex.com)

Internet: <http://www.batc.co.uk>

General:

Euratex Technical Clothing Group

rue Montoyer 24 box 10

B-1000 Brussels - Belgium

Tel.: 00/32/2/285.48.80

Fax: 00/32/2/230.60.54

E-mail: [info@euratex.org](mailto:info@euratex.org)

Internet: <http://www.euratex.org>

## II. GENERAL

### 2.1 Limits and field of application

**PART 1** of the Recommendations is limited to the characteristics of fabrics which are detectable by an experienced person with or without the aid of instruments in general use.

When it is thus possible to note an irregularity in relation to one of these characteristics, it will be considered as a "fault" on condition that this irregularity:

- is evident in the fabrics as delivered,
- is detrimental to the final garment.

**PART 2** of the Recommendations deals with the characteristics of fabrics which can only be noted with the aid of suitable equipment.

Each characteristic described in this document comprises:

- definition
- method of testing
- minimum quality standards

and as far as it occurs:

possible allowable tolerances compared with the values of the sample

Minimum quality standards of the fabrics are defined according to the different clothing items, i.e. of different end-use categories.

The clothing items considered are:

- |    |   |                             |
|----|---|-----------------------------|
| 1  | - | Trousers, shorts            |
| 2  | - | Skirts                      |
| 3  | - | Jackets                     |
| 4  | - | Coats                       |
| 5  | - | Knitwear                    |
| 6  | - | Anoraks                     |
| 7  | - | Pyjamas and Nightwear       |
| 8  | - | Shirts, Dresses and Blouses |
| 9  | - | Lingerie                    |
| 10 | - | Swimwear                    |
| 11 | - | Lining                      |

**PART 3** of the Recommendations deals with the information concerning characteristics not detailed in PART 1 and PART 2 and examples of documents which could be used to exchange product information.

The definition, method of testing, minimum quality standards and allowable tolerance of characteristics not described in this document will be decided by mutual agreement between the clothing manufacturer and the supplier.

Any incompatibility vis-à-vis these Recommendations must be brought to the attention of the purchaser beforehand.

## **2.2 Method of Testing**

The responsibility for testing the fabric before and controlling the delivery always rests with the supplier.

Before finalising the contract, the supplier will specify a standard sample to be used as reference. This sample can be: a reference sample or swatches of a typical length of the fabric.

In this document reference is made to EN and ISO methods of testing.

The European Committee for Standardization (CEN) and the International Organization for Standardisation (ISO) are studying methods of testing for certain characteristics. As soon as these are ratified or established, they will be the subject of an addendum to this document.

## **2.3 Tolerances**

The tolerances quoted in the text of this document referring to PART 1 indicate the limits within which the faults do not give rise to allowance.

The tolerances quoted in the text of this document referring to PART 2 indicate acceptable variations from the values given in the contract or found on the reference sample compared with the values noted on the fabric as delivered by the supplier.

## **2.4 Arbitration**

Any dispute or difference of opinion which may arise in the application of these Recommendations in respect of commercial dealings should be settled by mutual agreement between the parties.

## PART 1

|   |       |
|---|-------|
| <b>CONTENTS OF THIS PART</b>  | 15    |
| <b>III. Definitions, methods of measurement and of checking and tolerances.</b>                         | 16-32 |
| Category A.   | 16    |
| A1 Warpway (full or part length): thick or thin end, tight or slack end, missing end, double end.       | 16    |
| A2 Stripes in the warp.   | 16    |
| A3 Weftway thick or thin pick, tight or slack pick, missing pick, broken pick, double pick and trailer. | 17    |
| A4 Bars in the weft.  | 18    |
| A5 Knots or slubs in warps or weft threads.   | 18    |
| A6 Faulty mending and burling, tears, holes and stains.   | 19    |
| A7 Pieces cut in several parts ("throughs").  | 19    |
| Category B.   | 20    |
| B1 Design.  | 20    |
| B2 Mass per square metre (weight per square metre).   | 21    |
| B3 Length of the piece.   | 22    |
| B4 Length of an order.  | 22    |
| B5 Width.   | 23    |
| B6 Irregularity of checks along the piece.  | 23    |
| B7 Skew.  | 24    |
| B8 Bowing in the warp.  | 25    |
| B9 Relaxation shrinkage of non washable fabrics after steam pressing.                                   | 25    |
| Category C.   | 27    |
| C1 Variation in shade compared with the sample, within the piece and from piece to piece.               | 27    |
| C2 Difference in tension warpway between the body of the cloth and the selvages.                        | 27    |
| C3 Bowing of the weft.  | 28    |
| C4 Non-symmetrical distribution of design.  | 28    |
| C5 Make-up of the piece.  | 29    |
| C6 Finish.  | 30    |
| C7 Disagreeable odour.  | 30    |
| C8 Creases.   | 31    |
| C9 Foreign matter.  | 31    |
| Appendix 1 Concerning C1 Variation of shade along the piece (method of testing).                        | 32    |

### **III. DEFINITIONS, METHODS OF MEASUREMENT AND OF CHECKING, AND TOLERANCES.**

#### **CATEGORY A**

#### **A1 WARPWAY (FULL OR PART LENGTH): THICK OR THIN END, TIGHT OR SLACK END, MISSING END, DOUBLE END**

##### **A1.1. Definition of the Faults**

Thick or thin end: a warp thread that differs in diameter from the corresponding normal ends.

Tight or slack end: a warp thread or part of a warp thread, that is tighter or slacker than the corresponding normal ends.

Missing or broken end: the absence of a complete warp thread or part of a warp thread.

Double end: thread or part of thread in the warp which is accidentally doubled.

##### **A1.2 Method of Testing**

Visual assessment of those imperfections in the cloth which would be unacceptable in a garment, measurement of their lengths and counting the fault.

##### **A1.3 Tolerance**

The fault is tolerated if the residual cloth width satisfies the contract.

#### **A2 STRIPES IN THE WARP**

##### **A2.1 Definition of the Fault**

Stripes or streaks for full or part length warp way, showing up against the rest of the piece.

##### **A2.2 Method of Testing**

Visual assessment of those imperfections which would be unacceptable in a garment, and measurement of their lengths.

##### **A2.3 Tolerance**

The fault is tolerated if the residual cloth width meets the contract.



### **A3 WEFTWAY THICK OR THIN PICK, TIGHT OR SLACK PICK, MISSING PICK, BROKEN PICK, DOUBLE PICK AND TRAILER**

#### **A3.1 Definition of the Faults**

Thick or thin pick: a weft thread that differs in diameter from the corresponding normal picks.

Tight or slack pick: a weft thread, or part of a weft thread, that is tighter or slacker than the corresponding normal picks.

Missing pick: the unintentional omission of one complete pick across the full width of the cloth.

Broken pick: a pick that is inserted for only part of the cloth width.

Double pick: thread or pieces of thread in the weft which form the woven structure but are accidentally doubled.

Trailer: weft yarn that has been pulled inadvertently into the fabric during weaving.

#### **A3.2 Method of Testing**

Visual assessment of those imperfections in the cloth which would be unacceptable in a garment, and measurement of their lengths.

#### **A3.3 Tolerance**

For faults detected by the method of control (see A3.2), no tolerance is permitted.

## **A4 BARS IN THE WEFT**

### **A4.1 Definition of the Fault**

Streaks for full or part length weft ways, showing up against the rest of the piece.

### **A4.2 Method of Testing**

Visual assessment of those imperfections which would be unacceptable in a garment, measurement of their length and if they occur in sequence.

### **A4.3 Tolerance**

For faults detected by the method of control (see A4.2), no tolerance is permitted.

## **A5 KNOTS OR SLUBS IN WARP OR WEFT THREADS**

### **A5.1 Definition of the Fault**

Knots or slubs in some of the weft or warp threads, visible to an experienced person and which spoil the appearance of the face of the cloth.

### **A5.2 Method of Testing**

Visual assessment of those faults which would be unacceptable in a garment.

### **A5.3 Tolerance**

For faults detected by the method of control (see A5.2), no tolerance is permitted.

## **A6 FAULTY MENDING AND BURLING, TEARS, HOLES, STAINS**

### **A6.1 Definition of the Faults**

**Faulty mending:** poor appearance of repair on the face of the cloth.

**Faulty burling:** the presence of faults not removed during burling.

**Tears, cuts, holes:** various forms of cloth breakage.

**Stains:** areas of cloth contaminated with impurities.

### **A6.2 Method of Testing**

Visual assessment of those imperfections which would be unacceptable in a garment, and measurement of their lengths.

### **A6.3 Tolerance**

No tolerance permitted.

## **A7 PIECES CUT IN SEVERAL PARTS ("THROUGHS")**

### **A7.1 Definition of the Fault**

The piece is cut across the whole width in two or more parts, the total being equal to the required length.

### **A7.2 Method of Testing**

Verification that the number of the separate parts together make up the length ordered.

### **A7.3 Tolerance**

No tolerance permitted.

## CATEGORY B

### B1 DESIGN

#### B1.1 Definition of the Faults

A difference in design in relation to the sample, either:

- shade variation in ground or effect yarns or:
- the design dimensions differ from those specified in the contract.

#### Note

In the case of designs with a definite repeat (e.g. checks or stripes), the only disparity in question here is that occurring as between the delivered piece and the reference sample. Difference in the size of checks within the same piece are dealt with under fault reference B6, "Irregularity of Checks", see page 22.

#### B1.2 Method of Testing

##### Equipment

- a table at least as wide as the piece to be checked.
- ruler.

##### Procedure

Measure the length taken up by at least 10 repeats of the design. In the case of design repeating within less than 10 cm, measure at least one metre.

The measurement should be taken in an area of the cloth free from strings.

##### Results

The measurements obtained are compared with those stipulated in the contract or, where there is no such stipulation, with those from the reference sample.

The greatest plus or minus disparity is to be recorded.

#### B1.3 Tolerance

B1.3.1. In the case of design with a definite repeat (checks or stripes), the tolerance for measurements differing from those stipulated in the contract is as also mentioned under B6.3.

|                           |       |
|---------------------------|-------|
| Fabrics with visible weft | ±1,5% |
| Uni - coloured fabrics    | ±2,0% |
| Double jersey             | ±3,0% |
| Single jersey             | ±4%   |

B1.3.2 For designs not covered by B1.3.1. it is not possible to fix a tolerance.

## **B2 MASS PER SQUARE METRE (WEIGHT PER SQUARE METRE)**

### **B2.1 Definition of the Fault**

Difference of mass \* per square metre as compared with the particulars in the contract.

\* In practice the word "mass" is often replaced by "weight".

### **B2.2 Method of Testing**

The mass per square metre is taken to be the total weight of the piece divided by the exact length and the actual width including selvages.

In the case of dispute the cloth shall be tested in accordance with EN 12127.

### **B2.3 Tolerance**

+ / - 5%

## **B3 LENGTH OF THE PIECE**

### **B3.1 Definition of the Faults**

- B3.1.1. Delivered length (including faults) is different from the length of the piece as contracted.  
Length must be between 50 m and 100 m, for silk  $\pm 30$ m.  
Minimum length 20 m, for silk 10 m.
- B3.1.2. The length is defined as the distance between the markers at the head and tail ends of the piece.

### **B3.2 Method of Testing**

Routine checking will be carried out by means of a calibrated measuring machine having a tolerance of  $\pm 1\%$ . In the case of dispute, measurements will be made according to ISO 3933.

### **B3.3 Tolerance**

On the length of each delivered piece the following tolerances are allowed. compared to the length specified in the contract.

- $\pm 1\%$  for woven fabrics.
- $\pm 2\%$  for woven fabrics with elasthan.
- $\pm 2\%$  for knitted fabrics.
- $\pm 3\%$  for knitted fabrics with elasthan.

## **B4. LENGTH OF AN ORDER**

### **B4.1 Definition of the Fault**

Length delivered (in a particular type and colour) longer or shorter than the ordered length.

"Length delivered" means gross length, including any possible faults.

### **B4.2 Method of Testing**

Measure the length of each piece forming part of the order. Add up the resulting measurement.

### **B4.3 Tolerance**

Up to 2.000m:  $\pm 5\%$ , for silk up to 1.000m:  $\pm 5\%$ .  
From 2.000m:  $\pm 2\%$ , for silk from 1.000m:  $\pm 2\%$ .

## **B5 WIDTH**

### **B5.1 Definition of the Fault**

The usable width of the delivered piece is less than that specified on the contract.

### **B5.2 Method of Testing**

In the case of cloth with selvages, measure the smallest distance between the two selvages (the latter not being included in the measurement).

In the case of cloth without selvages, measure the smallest distance between the two edges of the cloth and deduct 1cm from each side.

Where the maker-up has expressly ordered a cloth without selvages which is to be usable over the whole width, the whole width is to be measured provided the piece is undamaged at the edges.

Cloths showing stenter-pin holes or marks are to be measured at the minimum width between the holes or marks.

The minimum width is to be measured on the cloth without tension.

In the case of dispute, measurements will be made according to ISO 3932.

### **B5.3 Tolerance**

No tolerance is allowed below the usable stipulated width in the contract. The maximum width must not exceed the usable stipulated width +4cm.

## **B6 IRREGULARITY OF CHECKS ALONG THE PIECE**

### **B6.1 Definition of the Fault**

The sizes of the checks are not identical right through the piece.

### **B6.2 Method of Testing**

With the cloth laid without tension on a flat, smooth surface, measure warp ways in several places the length occupied by a given number of checks, at least 5, the total length to be measured never being less than 70 cm.

In practice a pair of compasses can be used to determine whether there is a measurable difference.

### B6.3. Tolerance

|                           |       |
|---------------------------|-------|
| Fabrics with visible weft | ±1,5% |
| Uni - coloured fabrics    | ±2,0% |
| Double jersey             | ±3,0% |
| Single jersey             | ±4%   |

## B7 SKEW

### B7.1 Definition of the Fault

Weft not perpendicular to warp.

In the definition no account is taken as to whether the weft is linear or not. For this matter see fault C4: "Bowing in the Weft", page 25.

### B7.2 Method of Testing

N.F. G07 - 163 or BS 2819

The maximum difference of the pick and a line perpendicular to the weft is measured in cm.

This difference is related to both distances to the selvages. The highest result in % is recorded.

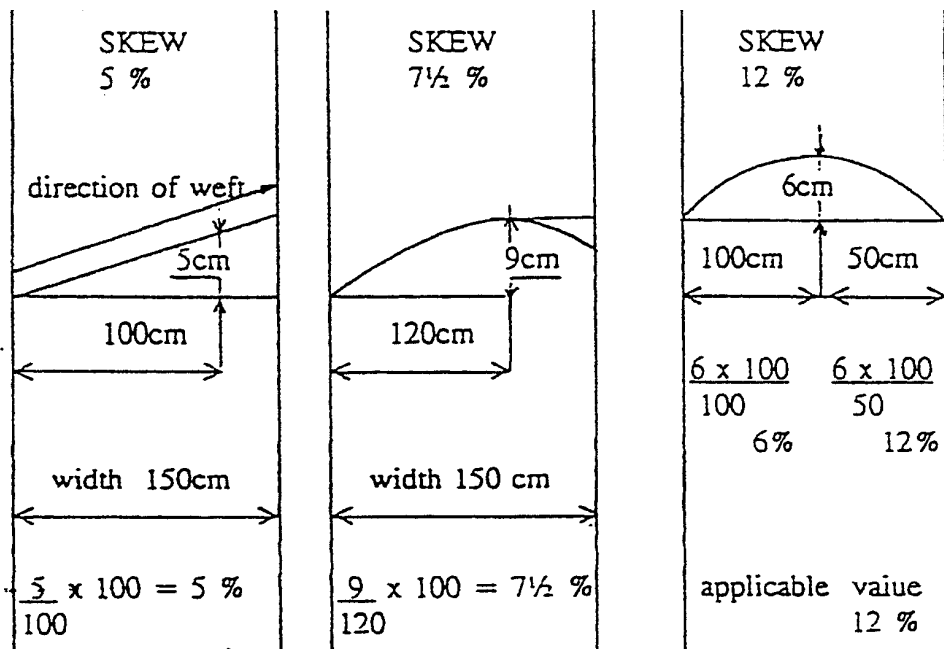



### **B7.3 Tolerance**

|  |      |
|--|------|
| Checks and fabrics with visible weft`                                | 1,5% |
| Woollen fabrics with visible weft                                    | 2,0% |
| Fabrics with invisible weft  | 3,0% |
| Charge of skew after washing<br>for cotton fabrics with natural skew | 3,0% |
| Double jersey  | 3,0% |
| Other knitted fabrics  | 4,0% |

## **B8 BOWING IN THE WARP**

### **B8.1 Definition of the Fault**

Bowing of the warp threads measured over a length of 1m

### **B8.2 Method of Testing**

Lay the part of the fabric to be tested flat and without tension.  
Place a steel rule so as to form a cord 1m long to the curved warp thread.  
Slide a graduated set square along the steel rule and record the greatest perpendicular distance between the warp thread and the steel rule.

### **B8.3 Tolerance**

1% related to the normal warp thread.

## **B9 RELAXATION SHRINKAGE OF NON WASHABLE FABRICS AFTER STEAM PRESSING**

### **B9.1 Definition of the Fault**

A permanent change in the dimensions of the fabric in warp and/or weft after steam pressing in the clothing industry.

### **B9.2 Method of Testing**

The test will be made on the fabric as delivered.

Modified Hoffmann press (DIN 53894) (part 2) using the following method:

Partly opened press.

5 times        {steaming 10 seconds  
                  {  
                  {vacuum 10 seconds

Conditioning is carried out in the atmosphere of the factory.

### B9.3 Tolerance

The following tolerances are recommended:

|      | Worsted | Woollen |
|------|---------|---------|
| Warp | 1,1 %   | 1,5 %   |
| Weft | 0,6 %   | 1,5 %   |

Elongation is not permitted.

#### Note

Since an excessive relaxation shrinkage modifies certain characteristics of the fabric such as width, length, mass, the following procedure must be applied: claims based on the fact that the characteristics quoted have been modified by shrinkage cannot be accepted if the shrinkage itself does not exceed the specified tolerances. If the shrinkage is larger, that fraction of the shrinkage which exceeds the tolerance may affect the characteristics, which may then be outside their own tolerances.

The appropriate method of test and tolerance will then apply.

#### Remarks.

In some countries the WIRA method ISO 3005 / NF G07-126 is adopted. See requirements

|                    |        | Worsted | Woollen |
|--------------------|--------|---------|---------|
| -Woven materials   | length | 3,5 %   | 1,5 %   |
|                    | width  | 2,5 %   | 1,0 %   |
| -Knitted materials | length | 4 %     |         |
|                    | width  | 4 %     |         |

## CATEGORY C

### **C1 VARIATION IN SHADE COMPARED WITH THE SAMPLE, WITHIN THE PIECE AND FROM PIECE TO PIECE.**

#### **C1.1 Definition of the Fault**

A difference in shade distinguished by an experienced person or by colorimetric technology.

#### **C1.2 Method of Testing**

Examination shall be carried out by an experienced person making use of a light source in accordance with the standard D65 of the International Commission on Illumination (CIE) at a level of 1000 to 1700 Lux (ISO 105 J01) or by colorimetric assessment.

#### **C1.3 Tolerance**

Visual assessment: It is not possible to set tolerances.

Colorimetric assessment:

Compared with sample:  $\Delta E_{1,2}$

Selvedge / centre of piece / selvedge:  $\Delta E_{0,5}$

Start of piece / end of piece:  $\Delta E_{0,5}$

Piece to piece:  $\Delta E_{1,2}$

### **C2 DIFFERENCE IN TENSION WARPWAY BETWEEN THE BODY OF THE CLOTH AND THE SELVEDGES**

#### **C2.1 Definition of the Fault**

Tight or slack selvedges as compared with the body of the cloth.

#### **C2.2 Method of Testing**

Visual observation

#### **C2.3 Tolerance**

No tolerance is accepted

### C3 BOWING OF THE WEFT

#### C3.1 Definition of the Fault

Bowing of the weft is any deviation of an individual pick from a straight line joining its two ends.

#### C3.2 Method of Testing

Measure the distance between two lines perpendicular to the selvages and tangent to the highest and lowest curve of the deformed weft. Express the bowing as a percentage to the nearest selvedge.

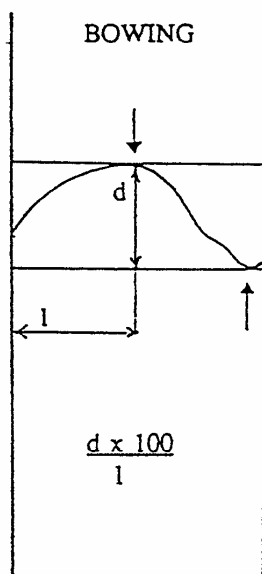

#### C3.3 Tolerance

1% related to the normal weft thread.

### C4 NON-SYMMETRICAL DISTRIBUTION OF DESIGN

#### C4.1 Definition of the Fault

Non-symmetrical distribution of the design motifs in relation to the centre of the cloth.

#### Note

This does not relate to fabrics where the design is deliberately unbalanced. In such a case the seller must seek the purchaser's agreement on the proposed distribution.

#### C4.2 Method of Testing

Working from the centre of the cloth width check by measurement that the motifs in both halves are equidistant from the centre, or rig the piece carefully, and check that the motifs in the respective halves correspond in position.

### **C4.3 Tolerances**

No tolerance is accepted.

## **C5 MAKE-UP OF THE PIECE**

### **C5.1 Definition of the Fault**

- (a) Rolling, rigging or cuttling different from that specified in the contract.
- (b) Imperfect rolling, rigging or cuttling.

### **C5.2 Method of Testing**

Visual examination of the piece.

### **C5.3 Tolerance**

for (a): No tolerance is permitted  
for (b): It is impossible to fix a tolerance.

### **C5.4 Recommendation for make-up of the piece**

Max. weight : 25 kg. (higher weight possible depending on equipment).

Diameter of tube : > 50 mm - <55 mm

Packaging : environmental friendly

## **C6 FINISH**

### **C6.1 Definition of the Fault**

A difference in the finish or the applied finishing agent as compared with the reference-sample, as regards either the appearance or the handle of the cloth.

### **C6.2 Method of Testing**

In the absence of a method for measuring certain characteristics of the cloth, a comparison is made by touch and sight between the finish of the reference-sample and that of the delivered cloth.

### **C6.3 Tolerance**

It is not possible to set a tolerance.

## **C7 DISAGREEABLE ODOUR**

### **C7.1 Definition of the Fault**

The cloth is accidentally contaminated with matter which causes disagreeable odours.

### **C7.2 Method of testing**

The fabric is stored in test containers during a predetermined time period and temperature. Determination of the odour is carried out by sense of smell by a number of persons using an evaluation scale.

### **C7.3 Tolerance**

No tolerance is accepted

## **C8 CREASES**

### **C8.1 Definition of the Fault**

Accidental creases visible in the delivered cloth.

### **C8.2 Method of Testing**

Examine the fabric in oblique lighting.

### **C8.3 Tolerance**

It is not possible to set a tolerance

## **C9 FOREIGN MATTER**

### **C9.1 Definition of the Fault**

Foreign matter distributed throughout the piece and visible on the cloth face.

### **C9.2 Method of Testing**

Visual examination of the cloth by an experienced person.

### **C9.3 Tolerance**

It is not possible to set a tolerance

## APPENDIX 1

### Concerning C1 VARIATION IN SHADE ALONG THE PIECE

**Method of Testing** is an assembly enabling colour variation weft way to be detected.

From the beginning of the piece remove a 15cm. strip of fabric over the full width.

Superimpose this strip at different places along the piece in order to examine the possible colour differences.

Cut from the other end of the piece another full width strip of 15cm and join it to the first strip by seaming parallel to the weft.

The composite strip thus formed is then in a way that the portions near the selvages are brought into the proximity of the portions from the centre of the piece (see figure 1).

Examine the assembled pattern.

If there are differences, steam the two stripes without pressure and re-examine them.

Figure 1

A and B represent the two selvages

A \_\_\_\_\_ B

Fold into two and sew at about 15cm from the selvages

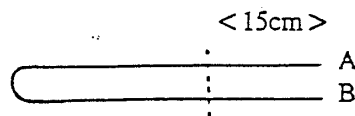

Cut at fold

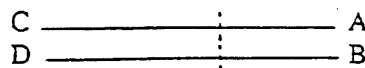

Fold the ends C and D so obtained on to the selvages A and B

[to complete]

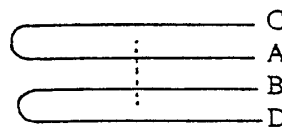

Sew about 2cm in from the edges A and C and B and D

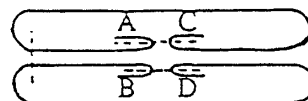

Examine the complete pattern

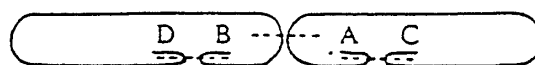



## PART 2

### CONTENTS OF THIS PART

33

|            |   |              |
|------------|---|--------------|
| <b>IV.</b> | <b>Characteristics (definitions, test methods, quality standards and tolerances).</b> | <b>34-60</b> |
| 1          | Colour fastness to light.   | 34           |
| 2          | Colour fastness to artificial weathering  | 35           |
| 3          | Colour fastness to perspiration.  | 36           |
| 4          | Colour fastness to dry cleaning using perchloroethylene.                              | 37           |
| 5          | Colour fastness to washing.   | 38           |
| 6          | Colour fastness to rubbing.   | 39           |
| 7          | Colour fastness to pressing or ironing.   | 40           |
| 8          | Colour fastness to spotting: water.   | 41           |
| 9          | Colour fastness to rubbing: organic solvents.   | 42           |
| 10         | Composition.  | 43           |
| 11         | Number of ends and picks.   | 44           |
| 12         | Weave.  | 45           |
| 13         | Breaking strength and elongation.   | 46           |
| 14         | Breaking strength (grab method).  | 47           |
| 15         | Tear strength.  | 48           |
| 16         | Seam slippage: Method 1   | 49           |
| 17         | Seam slippage: Method 2   | 50           |
| 18         | Resistance to abrasion.   | 51           |
| 19         | Resistance to pilling.  | 52           |
| 20         | Resistance to snagging.   | 53           |
| 21         | Dimension stability to washing.   | 54           |
| 22         | Dimension stability to dry cleaning.  | 55           |
| 23         | Crease recovery.  | 56           |
| 24         | Water-repellency  | 57           |
| 25         | Water-proofness   | 58           |
| 26         | Air permeability  | 59           |
| 27         | Resistance to hydrolysis  | 60           |

## IV. CHARACTERISTICS (DEFINITIONS, TEST METHODS, QUALITY STANDARDS, TOLERANCES)

### 1. COLOUR FASTNESS TO LIGHT

#### 1.1 Definition

Colour change under the influence of light.

#### 1.2 Method of Testing

EN ISO 105 B02

A sample of the fabric to be tested is exposed simultaneously with a range of eight blue wool standards to artificial light in an apparatus fitted with a xenon arc fading lamp. The humidity in the apparatus is being controlled.

#### 1.3 Minimum Quality Standards

Compared with the European blue wool standard.

| Trousers,<br>shorts | Skirts | Jackets | Coats | Knitwear | Anoraks<br>Skiwear<br>Sportswear | Pyjamas,<br>nightwear | Shirts,<br>Dresses,<br>Blouses | Lingerie | Swimwear | Lining |
|---------------------|--------|---------|-------|----------|----------------------------------|-----------------------|--------------------------------|----------|----------|--------|
| Change              |        |         |       |          |                                  |                       |                                |          |          |        |
| 5                   | 5      | 5       | 5     | 5        | 5                                | 4                     | 5                              | 4        | 5        | 4      |

## 2. COLOUR FASTNESS TO ARTIFICIAL WEATHERING

### 2.1 Definition

Colour change under the influence of artificial weather conditions.

### 2.2 Method of Testing

EN ISO 105 B04

A sample of the fabric to be tested is exposed simultaneously with a range of eight blue wool standards to simulated weathering conditions in an apparatus fitted with a xenon arc fading lamp. The method can be used to determine if a textile is wet light-sensitive.

### 2.3 Minimum Quality Standards

Compared with the European blue wool standard.

| Trousers,<br>shorts | Skirts | Jackets | Coats | Knitwear | Anoraks<br>Skiwear<br>Sportswear | Pyjamas,<br>nightwear | Shirts,<br>Dresses,<br>Blouses | Lingerie | Swimwear | Lining |
|---------------------|--------|---------|-------|----------|----------------------------------|-----------------------|--------------------------------|----------|----------|--------|
| Change              |        |         |       |          |                                  |                       |                                |          |          |        |
| 5                   | 5      | 5       | 5     | 5        | 5                                | 4                     | 5                              | 4        | 5        | 4      |

### 3. COLOUR FASTNESS TO PERSPIRATION

#### 3.1 Definition

The change and/or the staining of the dyed fabric under the influence of perspiration is determined.

#### 3.2 Method of Testing

EN ISO 105 E 04

A specimen of the fabric to be tested is brought in contact with white reference fabrics and then immersed in two solutions of histidine (one solution is acid, the other alkaline) and placed between two templates under a specified pressure in a test device, the so called “perspirometer”. The perspirometer is then placed during 4 hours in an oven with a temperature of 37°C. After the treatment the specimens are dried. The change in colour of the specimen under test is assessed with the grey scale for testing colour change, the staining to the reference fabrics is assessed with the grey scale for testing colour staining.

#### 2.3 Minimum Quality Standards

| Trousers,<br>shorts | Skirts | Jackets | Coats | Knitwear | Anoraks<br>Skiwear<br>Sportswear | Pyjamas,<br>nightwear | Shirts,<br>Dresses,<br>Blouses | Lingerie | Swimwear | Lining |
|---------------------|--------|---------|-------|----------|----------------------------------|-----------------------|--------------------------------|----------|----------|--------|
| Change              |        |         |       |          |                                  |                       |                                |          |          |        |
| 4                   | 4      | 4       | 4     | 4        | 4                                | 4                     | 4                              | 4        | 4        | 3-4    |
| Staining            |        |         |       |          |                                  |                       |                                |          |          |        |
| 4                   | 4      | 4       | 4     | 4        | 4                                | 4                     | 4                              | 4        | 4        | 3-4    |

Note:

If the garment is made up of white or light coloured parts next to dark ones, the staining must be 4-5 or better and dark colours must not bleed to light ones. The clothing manufacturer should specify this standard when drawing up the contract.

## 4. COLOUR FASTNESS TO DRY CLEANING USING PERCHLOROETHYLENE

### 4.1 Definition

The change and/or the staining of the dyed fabric under the influence of dry cleaning with perchloroethylene is determined.

### 4.2 Method of Testing

EN ISO 105 D 01

A specimen of the fabric to be tested is packed in a cotton fabric bag with non-corrodible steel discs and treated in laboratory washing equipment in cleaning solvent (perchloroethylene) during 30 minutes at 30°C. After drying the change in colour of the specimen under test is assessed with the grey scale for testing colour change.

### 4.3 Minimum Quality Standard

| Trousers,<br>shorts | Skirts | Jackets | Coats | Knitwear | Anoraks<br>Skiwear<br>Sportswear | Pyjamas,<br>nightwear | Shirts,<br>Dresses,<br>Blouses | Lingerie | Swimwear | Lining |
|---------------------|--------|---------|-------|----------|----------------------------------|-----------------------|--------------------------------|----------|----------|--------|
| Change              |        |         |       |          |                                  |                       |                                |          |          |        |
| 4                   | 4      | 4       | 4     | 4        | 4                                | 4                     | 4                              | 4        | 4        | 4      |

## 5. COLOUR FASTNESS TO WASHING

### 5.1 Definition

The change and/or the staining of the dyed fabric after washing is determined.

### 5.2 Method of Testing

EN ISO 105 C 06, C 08 and C 09.

A specimen of the fabric to be tested is brought in contact with white reference fabrics and washed in laboratory washing equipment for a predetermined time in a washing solution containing a specified detergent; the temperature depends on the article.

After rinsing and drying the change in colour of the specimen under test is assessed with the grey scale for testing colour change, the staining to the reference fabrics is assessed with the grey scale for testing colour staining.

### 5.3 Minimum Quality Standard

For all washable fabrics and linings:

| Trousers,<br>shorts | Skirts | Jackets | Coats | Knitwear | Anoraks<br>Skiwear<br>Sportswear | Pyjamas,<br>nightwear | Shirts,<br>Dresses,<br>Blouses | Lingerie | Swimwear | Lining |
|---------------------|--------|---------|-------|----------|----------------------------------|-----------------------|--------------------------------|----------|----------|--------|
| Change              |        |         |       |          |                                  |                       |                                |          |          |        |
| 4                   | 4      | *       | 4     | 4        | 4                                | 4                     | 4                              | 4        | 4        | 4      |
| Staining            |        |         |       |          |                                  |                       |                                |          |          |        |
| 4                   | 4      | *       | 4     | 4        | 4                                | 4                     | 4                              | 4        | 4        | 4      |

\* = Test not applicable to this product.

#### Note:

If the garment is made up of white or light coloured parts next to dark ones, the staining must be 4-5 or better and dark colours must not bleed to light ones. The clothing manufacturer should specify this standard when drawing up the contract.

## 6. COLOUR FASTNESS TO RUBBING

### 6.1 Definition

The staining of the dyed fabric after rubbing is determined.

### 6.2 Method of Testing

EN ISO 105 X 12

A well defined white piece of cloth, measuring 5cm x 5cm is mounted on the finger of a so called "crockmeter" and moved over the material to be tested 10 times over a distance of 10cm with a load of 9N. Two tests are carried out: one in warp direction and one in weft direction. Moreover dry rubbing and wet rubbing is tested.

Dry rubbing is carried out with a dry piece of cotton cloth, wet rubbing is carried out with a piece of cotton cloth which is wetted with demineralised or distilled water to 100% of its own weight. The staining to the reference fabrics is assessed with the grey scale for testing colour staining.

### 6.3 Minimum Quality Standard

| Trousers,<br>shorts | Skirts  | Jackets | Coats   | Knitwear | Anoraks<br>Skiwear<br>Sportswear | Pyjamas,<br>nightwear | Shirts,<br>Dresses,<br>Blouses | Lingerie | Swimwear | Lining  |
|---------------------|---------|---------|---------|----------|----------------------------------|-----------------------|--------------------------------|----------|----------|---------|
| Staining            |         |         |         |          |                                  |                       |                                |          |          |         |
| dry 4               | dry 4   | dry 4   | dry 4   | dry 4    | dry 4                            | dry 4                 | dry 4                          | dry 4    | dry 4    | dry 4   |
| Staining            |         |         |         |          |                                  |                       |                                |          |          |         |
| wet 3-4             | wet 3-4 | wet 3-4 | wet 3-4 | wet 3-4  | wet 3-4                          | wet 3-4               | wet 3-4                        | wet 3-4  | wet 3-4  | wet 3-4 |

## 7. COLOUR FASTNESS TO PRESSING OR IRONING

### 7.1 Definition

Change and or staining of the colour of the fabric after hot pressing.

### 7.2 Method of Testing

EN ISO 105 X 11

Tests are given for hot pressing when the textile is dry, when it is wet, and when it is damp. The end-use of the textile usually determines which test should be made. A dry specimen (dry pressing) or a dry specimen covered with a wet cotton adjacent fabric (damp pressing) or a wet specimen covered with a wet cotton adjacent fabric (wet pressing) are pressed with a heating device at a specified temperature and pressure for a specified time.

After the treatment the change in colour of the specimen under test is assessed with the grey scale for testing colour change, the staining to the reference fabrics is assessed with the grey scale for testing colour staining.

### 7.3 Minimum Quality Standard

| Trousers,<br>shorts | Skirts | Jackets | Coats | Knitwear | Anoraks<br>Skiwear<br>Sportswear | Pyjamas,<br>nightwear | Shirts,<br>Dresses,<br>Blouses | Lingerie | Swimwear | Lining |
|---------------------|--------|---------|-------|----------|----------------------------------|-----------------------|--------------------------------|----------|----------|--------|
| Change              |        |         |       |          |                                  |                       |                                |          |          |        |
| 4                   | 4      | 4       | 4     | 4        | 4                                | 4                     | 4                              | 4        | 4        | 3-4    |
| Staining            |        |         |       |          |                                  |                       |                                |          |          |        |
| 4                   | 4      | 4       | 4     | 4        | 4                                | 4                     | 4                              | 4        | 4        | 3-4    |



## 8. COLOUR FASTNESS TO SPOTTING: WATER

### 8.1 Definition

Change and or staining of the colour of the fabric after treatment with water drops.

### 8.2 Method of Testing

EN ISO 105 E 07

Drops of water are worked into the specimen with a glass rod, and the change in colour of the textile is assessed with the grey scale for testing colour change after 2 minutes and after drying.

### 8.3 Minimum Quality Standard

| Trousers,<br>shorts | Skirts | Jackets | Coats | Knitwear | Anoraks<br>Skiwear<br>Sportswear | Pyjamas,<br>nightwear | Shirts,<br>Dresses,<br>Blouses | Lingerie | Swimwear | Lining |
|---------------------|--------|---------|-------|----------|----------------------------------|-----------------------|--------------------------------|----------|----------|--------|
| Change              |        |         |       |          |                                  |                       |                                |          |          |        |
| 4                   | 4      | 4       | 4     | 4        | 4                                | 4                     | 4                              | 4        | 4        | 3-4    |

## 9. COLOUR FASTNESS TO RUBBING: ORGANIC SOLVENTS

### 9.1 Definition

The staining of the dyed fabric under the influence of rubbing is determined.

The colour or appearance of the fabric is determined simulating the removal of a stain using a solvent.

### 9.2 Method of Testing

EN ISO 105 D 02

Specifies a method for determining the resistance of the colour of textiles to localized "spotting" carried out by hand. A specimen of the textile is rubbed with rubbing cotton cloth impregnated with solvent. The change in colour of the specimen under test is assessed with the grey scale for testing colour change and the staining of the rubbing cotton cloth is assessed with the grey scale for testing colour staining

### 9.3 Minimum Quality Standards

| Trousers,<br>shorts | Skirts | Jackets | Coats | Knitwear | Anoraks<br>Skiwear<br>Sportswear | Pyjamas,<br>nightwear | Shirts,<br>Dresses,<br>Blouses | Lingerie | Swimwear | Lining |
|---------------------|--------|---------|-------|----------|----------------------------------|-----------------------|--------------------------------|----------|----------|--------|
| Change              |        |         |       |          |                                  |                       |                                |          |          |        |
| 4-5                 | 4-5    | 4-5     | 4-5   | 4-5      | 4-5                              | 4-5                   | 4-5                            | 4-5      | 4-5      | 4-5    |
| Staining            |        |         |       |          |                                  |                       |                                |          |          |        |
| 4-5                 | 4-5    | 4-5     | 4-5   | 4-5      | 4-5                              | 4-5                   | 4-5                            | 4-5      | 4-5      | 4-5    |

## **10. COMPOSITION**

### **10.1 Definition**

The natures of the fibres of the fabric and/or their proportion in the case of a mixture differs from the conditions stipulated in the contract.

### **10.2 Method of Testing**

In countries of the European Union.

Directive 96/73/EC of the European Parliament and the Council of 16 December 1996 on certain methods for the quantitative analysis of binary textile fibre mixtures.

Directive 96/74/EC of the European Parliament and the Council of 16 December 1996 on textile names.

Directive 97/37/EC of the Commission of 19 June 1997.

Directive 2004/34/EC of the Commission of 23 March 2004.

Outside the European Union unless there are special regulations.

ISO 5089 Textiles - Preparation of laboratory test samples and test specimens for chemical testing.

ISO 1833 Textiles - Binary fibre mixtures - Quantitative chemical analysis.

ISO 5088 Textiles - Ternary fibre mixtures - Quantitative analysis.

### **10.3 Minimum Quality Standard**

Not relevant for this characteristic.

### **10.4 Tolerances**

Refer to EU Directives or the national legislation in force.

## **11. NUMBER OF ENDS AND PICKS**

### **11.1 Definition**

The number of the ends and/or picks per centimetre, warp yarn and/or weft yarn of the fabric delivered, does not comply with the specification set out in the contract or with those of the standard sample.

### **11.2 Method of Testing**

EN 1049-2 and ISO 7211-2

Three methods of determining the number of threads per centimetre are included, any of which may be used, the choice depending on the character of the fabric. The principles are as follows: Method A: A section of fabric of dimension specified is dissected and the number of threads counted. The threads that are to be counted are preferably short, 1 or 2 cm being suitable. Method B: the number of threads visible within the aperture of a defined counting glass is determined. Method C: the number of threads per centimetre of the fabric is determined with the aid of a traversing thread counter.

### **11.3 Minimum Quality Standard**

Not relevant for this characteristic.

### **11.4 Tolerance**

6% for carded fabrics.  
4% for all other fabrics.

## **12. WEAVE**

### **12.1 Definition**

A different weave from that of the typical sample or that specified in the contract.

### **12.2 Method of Testing**

Testing will be carried out according to ISO 7211-1.

### **12.3 Minimum Quality Standards**

Not relevant for this characteristic.

### **12.4 Tolerance**

No difference is allowed.

## 13. BREAKING STRENGTH AND ELONGATION

### 13.1 Definition

The breaking strength and elongation necessary for fabrics and linings for garments are lower than: the necessary minimum values or the values specified in the contract or in the absence of these, of the typical sample.

### 13.2 Method of Testing

EN-ISO 13934-1

Specifies a procedure to determine the maximum force and elongation at this maximum force of textile fabrics using a strip method. The method is mainly applicable to woven textile fabrics. It can be applicable to fabrics produced by other techniques. Specifies the determination of the maximum force and elongation at maximum force of test specimens in equilibrium with the standard atmosphere for testing, and of test specimens in the wet state.

### 13.3 Minimum Quality Standards

| Trousers,<br>shorts | Skirts          | Jackets         | Coats           | Knitwear | Anoraks<br>Skiwear | Sportswear      | Pyjamas,<br>nightwear | Shirts,<br>Dresses,<br>Blouses | Lingerie        | Swimwear        | Lining           |
|---------------------|-----------------|-----------------|-----------------|----------|--------------------|-----------------|-----------------------|--------------------------------|-----------------|-----------------|------------------|
| <b>Full fit</b>     |                 |                 |                 |          |                    |                 |                       |                                |                 |                 |                  |
| Strength            |                 |                 |                 |          |                    |                 |                       |                                |                 |                 |                  |
| 25 daN              | 25 daN          | 20 daN          | 20 daN          | *        | 25 daN             | 18 daN          | 18 daN                | 18 daN                         | 22 daN          | 18 daN          |                  |
| Elongation in %     |                 |                 |                 |          |                    |                 |                       |                                |                 |                 |                  |
| 12,5<br>-<br>55     | 12,5<br>-<br>55 | 12,5<br>-<br>40 | 12,5<br>-<br>55 | *        | 12,5<br>-<br>55    | 12,5<br>-<br>40 | 12,5<br>-<br>40       | 12,5<br>-<br>40                | 12,5<br>-<br>40 | 12,5<br>-<br>40 | 7,5<br>-<br>32,5 |
| <b>Tight fit</b>    |                 |                 |                 |          |                    |                 |                       |                                |                 |                 |                  |
| Strength            |                 |                 |                 |          |                    |                 |                       |                                |                 |                 |                  |
| 30 daN              | 30 daN          | 20 daN          | 20 daN          | *        | 25 daN             | 22 daN          | 22 daN                | 22 daN                         | 22 daN          | 22 daN          | 22 daN           |
| Elongation in %     |                 |                 |                 |          |                    |                 |                       |                                |                 |                 |                  |
| 12,5<br>-<br>55     | 12,5<br>-<br>55 | 12,5<br>-<br>40 | 12,5<br>-<br>55 | *        | 12,5<br>-<br>55    | 12,5<br>-<br>55 | 12,5<br>-<br>55       | 12,5<br>-<br>55                | 12,5<br>-<br>55 | 12,5<br>-<br>40 | 7,5<br>-<br>32,5 |

\* = Test not applicable to this product.

### 13.4 Tolerances

No tolerance allowed if the value given in the contract is a minimum one.  
10% below the value given in the contract or that of the standard sample.

1 daN equals approximately 1 kilogram force

1 daN = 1,02 kgf

## 14. BREAKING STRENGTH (GRAB METHOD)

### 14.1 Definition

The breaking strength from fabrics must not be below the necessary minimum value or the values specified in the contract or in the absence of these, of the typical sample.

### 14.2 Method of Testing

EN-ISO 13934-2

Specifies a procedure for the determination of the maximum force of textile fabrics known as the grab test. The method is mainly applicable to woven textile fabrics. It may be applicable to fabrics produced by other techniques. The method specifies the determination of the maximum force of test specimens in equilibrium with the standard atmosphere for testing and of test specimens in the wet state. The method is restricted to the use of constant rate of extension (CRE) testing machines.

### 14.3 Minimum Quality Standards

| Trousers,<br>shorts | Skirts | Jackets | Coats  | Knitwear | Anoraks<br>Skiwear<br>Sportswear | Pyjamas,<br>nightwear | Shirts,<br>Dresses,<br>Blouses | Lingerie | Swimwear | Lining |
|---------------------|--------|---------|--------|----------|----------------------------------|-----------------------|--------------------------------|----------|----------|--------|
| <b>Full fit</b>     |        |         |        |          |                                  |                       |                                |          |          |        |
| Strength            |        |         |        |          |                                  |                       |                                |          |          |        |
| 18 daN              | 18 daN | 15 daN  | 15 daN | *        | 18 daN                           | 12 daN                | 12 daN                         | 12 daN   | 15 daN   | 12 daN |
| <b>Tight fit</b>    |        |         |        |          |                                  |                       |                                |          |          |        |
| Strength            |        |         |        |          |                                  |                       |                                |          |          |        |
| 20 daN              | 20 daN | 15 daN  | 15 daN | *        | 18 daN                           | 15 daN                | 15 daN                         | 15 daN   | 15 daN   | 15 daN |

\* = Test not applicable to this product.

### 14.4 Tolerances

No tolerance allowed if the value given in the contract is a minimum one.

1 daN equals approximately 1 kgf

1 daN = 1,02 kgf

## 15. TEAR STRENGTH

### 15.1 Definition

Resistance of a fabric to a tearing force, or resistance of a fabric to tear less than the characteristics set out in the contract or otherwise to those found in the standard sample provided.

### 15.2 Method of Testing

EN-ISO 13937-1

Textiles - Tear properties of fabrics - Part 1: Determination of tear force using ballistic pendulum method (Elmendorf).

Describes a method known as the ballistic pendulum (Elmendorf) method for the determination of tear force of textile fabrics. The method describes the measurement of the tear force required to propagate a single-rip tear of defined length from a cut in a fabric when a sudden force is applied.

### 15.3 Minimum Quality Standards

| Trousers,<br>shorts | Skirts     | Jackets    | Coats      | Knitwear | Anoraks<br>Skiwear<br>Sportswear | Pyjamas,<br>nightwear | Shirts,<br>Dresses,<br>Blouses | Lingerie   | Swimwear   | Lining     |
|---------------------|------------|------------|------------|----------|----------------------------------|-----------------------|--------------------------------|------------|------------|------------|
| <b>Full fit</b>     |            |            |            |          |                                  |                       |                                |            |            |            |
| Strength            |            |            |            |          |                                  |                       |                                |            |            |            |
| 1,5<br>daN          | 1,5<br>daN | 1,2<br>daN | 1,2<br>daN | *        | 1,2<br>daN                       | 0,8<br>daN            | 0,8<br>daN                     | 0,8<br>daN | 1,0<br>daN | 0,8<br>daN |
| <b>Tight fit</b>    |            |            |            |          |                                  |                       |                                |            |            |            |
| Strength            |            |            |            |          |                                  |                       |                                |            |            |            |
| 1,6<br>daN          | 1,6<br>daN | 1,2<br>daN | 1,2<br>daN | *        | 1,2<br>daN                       | 1,0<br>daN            | 1,0<br>daN                     | 1,0<br>daN | 1,0<br>daN | 1,0<br>daN |

\* = Test not applicable to this product.

### 15.4 Tolerances

7% below value given in the contract or to that of the sample provided.

No tolerance allowed if the value given in the contract is a minimum one.



## 16. SEAM SLIPPAGE: METHOD 1

### 16.1 Definition

Displacement of the yarn used for the fabric due to a force exerted perpendicularly to the seam and producing an opening parallel to the seam.

### 16.2 Method of Testing

EN-ISO 13936-1

Textiles - Determination of the slippage resistance of yarns at a seam in woven fabrics - **Part 1: Fixed seam opening method.**

This part of ISO 13936 is intended for the determination of the resistance offered by thread systems of woven fabric, to slippage at a sewn seam. This method is not suitable for stretch fabrics or for industrial fabrics, e.g. beltings.

### 16.3 Minimum Quality Standards

| Trousers,<br>shorts       | Skirts                    | Jackets                   | Coats                     | Knitwear | Anoraks<br>Skiwear<br>Sportswear | Pyjamas,<br>nightwear     | Shirts,<br>Dresses,<br>Blouses | Lingerie                  | Swimwear                  | Lining                    |
|---------------------------|---------------------------|---------------------------|---------------------------|----------|----------------------------------|---------------------------|--------------------------------|---------------------------|---------------------------|---------------------------|
| <b>Full fit</b>           |                           |                           |                           |          |                                  |                           |                                |                           |                           |                           |
| 4 mm at<br>14 daN<br>load | 4 mm at<br>14 daN<br>load | 4 mm at<br>12 daN<br>load | 4 mm at<br>14 daN<br>load | *        | 4 mm at<br>14 daN<br>load        | 4 mm at<br>10 daN<br>load | 4 mm at<br>11 daN<br>load      | 4 mm at<br>10 daN<br>load | 4 mm at<br>14 daN<br>load | 4 mm at<br>10 daN<br>load |
| <b>Tight fit</b>          |                           |                           |                           |          |                                  |                           |                                |                           |                           |                           |
| 4 mm at<br>16 daN<br>load | 4 mm at<br>16 daN<br>load | 4 mm at<br>12 daN<br>load | 4 mm at<br>14 daN<br>load | *        | 4 mm at<br>14 daN<br>load        | 4 mm at<br>12 daN<br>load | 4 mm at<br>12 daN<br>load      | 4 mm at<br>12 daN<br>load | 4 mm at<br>14 daN<br>load | 4 mm at<br>12 daN<br>load |

\* = Test not applicable to this product.

## 17. SEAM SLIPPAGE: METHOD 2

### 17.1 Definition

Displacement of the yarn used for the fabric due to a force exerted perpendicularly to the seam and producing an opening parallel to the seam.

### 17.2 Method of Testing

EN-ISO 13936-2

Textiles - Determination of the slippage resistance of yarns at a seam in woven fabrics - **Part 2: Fixed load method.**

Load: 6 daN for fabrics with a mass / m<sup>2</sup> of < 220 g / m<sup>2</sup>.

Load: 12 daN for fabrics with a mass / m<sup>2</sup> of > 220 g / m<sup>2</sup>.

This part of ISO 13936 is intended for the determination of the resistance offered by thread systems of woven fabric, to slippage at a sewn seam. This method is suitable for all apparel and upholstery woven fabrics, stretch fabrics (including those containing elastomeric yarn). It is not suitable for industrial fabrics, e.g. beltings.

### 17.3 Minimum Quality Standards

| Trousers, shorts          | Skirts                    | Jackets                   | Coats                     | Knitwear | Anoraks<br>Skiwear<br>Sportswear | Pyjamas,<br>nightwear    | Shirts,<br>Dresses,<br>Blouses | Lingerie                 | Swimwear                 | Lining                   |
|---------------------------|---------------------------|---------------------------|---------------------------|----------|----------------------------------|--------------------------|--------------------------------|--------------------------|--------------------------|--------------------------|
| <b>Full fit</b>           |                           |                           |                           |          |                                  |                          |                                |                          |                          |                          |
| 12 daN<br>load at 3<br>mm | 12 daN<br>load at<br>3 mm | 12 daN<br>load at<br>4 mm | 12 daN<br>load at<br>4 mm | *        | 12 daN<br>load at<br>4 mm        | 6 daN<br>load at<br>3 mm | 6 daN<br>load at<br>3 mm       | 6 daN<br>load at<br>3 mm | 6 daN<br>load at<br>3 mm | 6 daN<br>load at<br>3 mm |
| <b>Tight fit</b>          |                           |                           |                           |          |                                  |                          |                                |                          |                          |                          |
| 12 daN<br>load at 2<br>mm | 12 daN<br>load at<br>2 mm | 12 daN<br>load at<br>3 mm | 12 daN<br>load at<br>3 mm | *        | 12 daN<br>load at<br>3 mm        | 6 daN<br>load at<br>2 mm | 6 daN<br>load at<br>2 mm       | 6 daN<br>load at<br>2 mm | 6 daN<br>load at<br>2 mm | 6 daN<br>load at<br>3 mm |

\* = Test not applicable to this product.

## 18. RESISTANCE TO ABRASION

### 18.1 Definition

Fabric wears out too quickly for normal use.

### 18.2 Method of Testing

EN-ISO 12947-2

Textiles - Determination of abrasion resistance of fabrics by the Martindale method Part 2: Determination of specimen breakdown.

Is applicable to the determination of the inspection interval to breakdown of specimens covering all textile fabrics including nonwovens apart from fabrics where the specifier indicates the end performance as having a low abrasion wear life.

### 18.3 Minimum Quality Standards

| Trousers,<br>shorts   | Skirts         | Jackets        | Coats          | Knitwear        | Anoraks<br>Skiwear<br>Sportswear | Pyjamas,<br>nightwear | Shirts,<br>Dresses,<br>Blouses | Lingerie       | Swimwear       | Lining         |
|-----------------------|----------------|----------------|----------------|-----------------|----------------------------------|-----------------------|--------------------------------|----------------|----------------|----------------|
| <b>Pressure 9 kPa</b> |                |                |                |                 |                                  |                       |                                |                |                |                |
| 20.000<br>revs.       | 20.000<br>revs | 16.000<br>revs | 16.000<br>revs | 8.000<br>revs.* | 16.000<br>revs                   | 10.000<br>revs        | 12.000<br>revs                 | 10.000<br>revs | 20.000<br>revs | 10.000<br>revs |

\* = Depending on type of article (from T-shirt till jumper/sweater).

## 19. RESISTANCE TO PILLING

### 19.1 Definition

The fabric tends to pill quickly and the pills remain on the cloth.

### 19.2 Method of Testing

EN-ISO 12945-2 Textiles - Determination of fabric propensity to surface fuzzing and to pilling - Part 2: Modified Martindale method.

Specifies a method for determination of the resistance to pilling and surface change of textile fabrics using a modified Martindale method.

### 19.3 Minimum Quality Standards

| Trousers, shorts                  | Skirts | Jackets | Coats | Knitwear   | Anoraks<br>Skiwear<br>Sportswear | Pyjamas,<br>nightwear | Shirts,<br>Dresses,<br>Blouses | Lingerie | Swimwear | Lining |
|-----------------------------------|--------|---------|-------|--|----------------------------------|-----------------------|--------------------------------|----------|----------|--------|
| Woven fabrics                     |        |         |       | after 125 revolutions: 4<br>after 500 revolutions: 4<br>after 1.000 revolutions: 4<br>after 2.000 revolutions: 4 |                                  |                       |                                |          |          |        |
| Woven fabrics with raised surface |        |         |       | after 125 revolutions: 3-4<br>after 500 revolutions: 3<br>after 1.000 revolutions: 2-3                           |                                  |                       |                                |          |          |        |
| Knitwear                          |        |         |       | after 125 revolutions: 3-4<br>after 500 revolutions: 3<br>after 1.000 revolutions: 2-3                           |                                  |                       |                                |          |          |        |

## 20. RESISTANCE TO SNAGGING

### 20.1 Definition

The resistance of a fabric to the pulling or plucking of yarns or filaments from a fabric surface.

### 20.2 Method of Testing

ASTM D 3939 - 93

A fabric specimen in tubular form is mounted on a rotating cylinder. A mace (spiked ball) bounces randomly over the specimen thus causing snags to a certain degree.

The degree of snagging is evaluated with standard photographs (5 = no snagging, 1 = very severe snagging).

### 20.3 Minimum Quality Standards

| Trousers,<br>shorts | Skirts | Jackets | Coats | Knitwear | Anoraks<br>Skiwear<br>Sportswear | Pyjamas,<br>nightwear | Shirts,<br>Dresses,<br>Blouses | Lingerie | Swimwear | Lining |
|---------------------|--------|---------|-------|----------|----------------------------------|-----------------------|--------------------------------|----------|----------|--------|
| 3                   | 3      | 3       | 3     | 2-3      | 3                                | 3                     | 3                              | 3        | 3        | 3      |

### 20.4 Tolerances

No tolerance is allowed compared with the minimum standard.

## 21. DIMENSIONAL STABILITY TO WASHING

### 21.1 Definition

Change in dimensions of fabric sold as washable after washing.

### 21.2 Method of Testing

ISO 5077 Textiles - Determination of dimensional change in washing and drying

This standard specifies a method for determination of the dimensional change of fabrics, garment or other textile articles when subjected to an appropriate combination of specified washing and drying procedures. In the case of textile articles or deformable materials, it is necessary to exercise all possible caution in the interpretation of the results.

EN-ISO 6330 Textiles - Domestic washing and drying procedures for textile testing

Specifies domestic washing and drying procedures for textile testing. The procedures are applicable to textile fabrics, garments or other textile articles which are subjected to appropriate combinations of domestic washing and drying procedures

### 21.3 Minimum Quality Standards

| Trousers,<br>shorts | Skirts | Jackets | Coats | Knitwear   | Anoraks<br>Skiwear<br>Sportswear | Pyjamas,<br>nightwear | Shirts,<br>Dresses,<br>Blouses | Lingerie | Swimwear | Lining |
|---------------------|--------|---------|-------|------------|----------------------------------|-----------------------|--------------------------------|----------|----------|--------|
| Length              |        |         |       |            |                                  |                       |                                |          |          |        |
| -2%                 | -2%    | *       | -2%   | -6%<br>+2% | -3%                              | -2%                   | -2%                            | -2%      | -2%      | -3%    |
| Width               |        |         |       |            |                                  |                       |                                |          |          |        |
| -2%                 | -2%    | *       | -2%   | -6%<br>+2% | -3%                              | -2%                   | -2%                            | -2%      | -2%      | -3%    |

\* = Test not applicable to this product.

## 22. DIMENSIONAL STABILITY TO DRY CLEANING

### 22.1 Definition

Change in dimension after dry cleaning.

### 22.2 Method of Testing

EN-ISO 3175-1 Textiles - Dry-cleaning and finishing - Part 1: Method for assessing the cleanability of textiles and garments

Describes dry-cleaning test methods using a commercial dry-cleaning machine. Fabric and garment properties which may change on dry-cleaning and finishing are identified and methods for assessing change using existing International Standards are given as appropriate. Other properties which are also important, but for which no International Standard methods of assessment are available are also indicated, in annex A, together with advice on how to proceed on their assessment, and it is recommended that comments on these should be included in the test report.

Test a sample previously submitted to the test B 9.2 (page 24) given in the first part of the Recommendations.

Carry out 3 dry cleaning cycles using perchloroethylene (in charged bath) in an industrial dry cleaning machine.

### 22.3 Minimum Quality Standards

| Trousers,<br>shorts | Skirts | Jackets | Coats | Knitwear | Anoraks<br>Skiwear<br>Sportswear | Pyjamas,<br>nightwear | Shirts,<br>Dresses,<br>Blouses | Lingerie | Swimwear | Lining |
|---------------------|--------|---------|-------|----------|----------------------------------|-----------------------|--------------------------------|----------|----------|--------|
| Length              |        |         |       |          |                                  |                       |                                |          |          |        |
| 1,5%                | 1,5%   | 1,5%    | 1,5%  | 2,5%     | 1,5%                             | 1,5%                  | 1,5%                           | 1,5%     | 1,5%     | 1,5%   |
| Width               |        |         |       |          |                                  |                       |                                |          |          |        |
| 1,5%                | 1,5%   | 1,5%    | 1,5%  | 2,5%     | 1,5%                             | 1,5%                  | 1,5%                           | 1,5%     | 1,5%     | 1,5%   |

## 23. CREASE RECOVERY

### 23.1 Definition

Insufficient crease recovery properties of the fabric.

### 23.2 Method of Testing

ISO 2313 Textile fabrics - Determination of the recovery from creasing of a horizontally folded specimen by measuring the angle of recovery.

This Standard specifies a method for determining the angle of recovery of fabrics from creasing. The results obtained by this method for textile fabrics of very different kinds cannot be compared directly. Attention is drawn to the fact that for some types of fabrics, the limpness, thickness and tendency to curl of the specimen may give rise to very ill-defined crease recovery angles, and therefore an unacceptable lack of precision in making measurements. Many wool and wool mixtures fabrics come under this heading.

ISO 9867 Textiles - Evaluation of the wrinkle recovery of fabrics - Appearance method.

Contains a method in order to evaluate the appearance of textile fabrics after induced wrinkling. Describes the principle, the apparatus, the atmospheres for conditioning and testing, the test specimens, the test procedure, the evaluation and the contents of the test report.

### 23.3 Minimum Quality Standards

| Trousers,<br>shorts | Skirts        | Jackets       | Coats         | Knitwear | Anoraks<br>Skiwear<br>Sportswear | Pyjamas,<br>nightwear | Shirts,<br>Dresses,<br>Blouses | Lingerie | Swimwear | Lining |
|---------------------|---------------|---------------|---------------|----------|----------------------------------|-----------------------|--------------------------------|----------|----------|--------|
| ISO 2313            |               |               |               |          |                                  |                       |                                |          |          |        |
| 110°-<br>120°       | 110°-<br>120° | 110°-<br>120° | 110°-<br>120° | *        | 110°-<br>120°*                   | *                     | 110°-<br>120°*                 | *        | *        | *      |
| ISO 9867            |               |               |               |          |                                  |                       |                                |          |          |        |
| 4                   | 4             | 4             | 4             | *        | 4*                               | *                     | 4*                             | *        | *        | *      |

\* = Test not applicable to this product.



## 24. WATER-REPELLENCY

### 24.1 Definition

Insufficient water-repellent properties of the fabric.

### 24.2 Method of Testing

ISO 4920 Textile fabrics - Determination of resistance to surface wetting (Spray test)

This Standard specifies a spray test method for determining the resistance of any fabric - which may or may not have been given a water-resistance or water-repellent finish - to surface wetting by water. It is not intended for use in predicting the rain penetration resistance of fabrics, since it does not measure penetration of water through the fabric.

### 24.3 Minimum Quality Standards

| Trousers,<br>shorts  | Skirts | Jackets | Coats<br>Rainwear | Knitwear | Anoraks<br>Skiwear<br>Sportswear | Pyjamas,<br>nightwear | Shirts,<br>Dresses,<br>Blouses | Lingerie | Swimwear | Lining |
|----------------------|--------|---------|-------------------|----------|----------------------------------|-----------------------|--------------------------------|----------|----------|--------|
| New                  |        |         |                   |          |                                  |                       |                                |          |          |        |
| *                    | *      | *       | 5                 | *        | 5                                | *                     | *                              | *        | *        | *      |
| After care treatment |        |         |                   |          |                                  |                       |                                |          |          |        |
| *                    | *      | *       | 3                 | *        | 3                                | *                     | *                              | *        | *        | *      |

\* = Test not applicable to this product.

## 25. WATER-PROOFNESS

### 25.1 Definition

Insufficient water-proof properties of the fabric.

### 25.2 Methods of Testing

ISO 811 Textile fabrics - Determination of resistance to water penetration - Hydrostatic pressure test

This Standard specifies a hydrostatic pressure method for determining the resistance of fabrics to penetration by water. The method is primarily intended for dense fabrics, e.g. ducks, tarpaulins and tentings

EN 343 Protective clothing - Protection against rain

This European Standard specifies requirements and test methods applicable to materials and seams of protective clothing against the influence of precipitation (.e.g. rain, snowflakes), fog, ground humidity and wind. The testing of rain proofness of ready made garments is excluded in this standard at this time because a separate test method for such a property is currently being prepared.

### 25.3 Minimum Quality Standards

| Trousers,<br>shorts | Skirts | Jackets | Coats<br>Rainwear | Knitwear | Anoraks<br>Skiwear<br>Sportswear | Pyjamas,<br>nightwear | Shirts,<br>Dresses,<br>Blouses | Lingerie | Swimwear | Lining |
|---------------------|--------|---------|-------------------|----------|----------------------------------|-----------------------|--------------------------------|----------|----------|--------|
| Weather resistant   |        |         |                   |          |                                  |                       |                                |          |          |        |
| *                   | *      | *       | 130<br>mBar       | *        | 130<br>mBar                      | *                     | *                              | *        | *        | *      |
| Fashion             |        |         |                   |          |                                  |                       |                                |          |          |        |
| *                   | *      | *       | 80<br>mBar        | *        | 80<br>mBar                       | *                     | *                              | *        | *        | *      |

\* = Test not applicable to this product.

## 26. AIR PERMEABILITY

### 26.1 Definition

Insufficient air permeability properties of the fabric.

### 26.2 Method of Testing

EN-ISO 9237 Textiles - Determination of permeability of fabrics to air

Is applicable to most types of fabrics, including industrial fabrics for technical purposes, nonwovens and made-up textile articles that are permeable to air.

### 26.3 Minimum Quality Standards

| Trousers,<br>shorts       | Skirts | Jackets | Coats<br>Rainwear                   | Knitwear | Anoraks<br>Skiwear<br>Sportswear    | Pyjamas,<br>nightwear | Shirts,<br>Dresses,<br>Blouses | Lingerie | Swimwear | Lining |
|---------------------------|--------|---------|-------------------------------------|----------|-------------------------------------|-----------------------|--------------------------------|----------|----------|--------|
| Depending on requirements |        |         |                                     |          |                                     |                       |                                |          |          |        |
| *                         | *      | *       | 25<br>mm/s<br>(l/m <sup>2</sup> ·s) | *        | 25<br>mm/s<br>(l/m <sup>2</sup> ·s) | *                     | *                              | *        | *        | *      |

\* = Test not applicable to this product.

## 27. RESISTANCE TO HYDROLYSIS

### 27.1 Definition

Insufficient resistance to hydrolysis properties of the fabric.

### 27.2 Method of Testing

EN 12447 Geotextiles and geotextile-related products - Screening test method for determining the resistance to hydrolysis in water

This test method is also applicable to coated materials used in apparel.

Specifies a screening test method for determining the resistance of geotextiles and geotextile-related products to hydrolysis by exposing test specimens to water at elevated temperatures, followed by an evaluation of the changes in properties resulting from such exposure. It is intended as a means of establishing a minimum acceptable level of durability. The test is applicable to any geotextile and geotextile-related product susceptible to hydrolysis, in particular polyester and polyamide based materials, and in addition to the yarns from which these geotextiles are made. Reinforcing materials shall be tested without the coating and manufacturers shall ensure that the degradation of the coating will not attack or have any negative influence on the degradation of the yarns.

### 27.3 Minimum Quality Standards

| Trousers, shorts  | Skirts | Jackets | Coats<br>Rainwear | Knitwear | Anoraks<br>Skiwear<br>Sportswear | Pyjamas,<br>nightwear | Shirts,<br>Dresses,<br>Blouses | Lingerie | Swimwear | Lining |
|---|--------|---------|-------------------|----------|----------------------------------|-----------------------|--------------------------------|----------|----------|--------|
| Test conditions: 70°C, 95% relative humidity, minimum 7 days  |        |         |                   |          |                                  |                       |                                |          |          |        |
| No sticking, no delamination, no significant change of the appearance, no significant change of properties. |        |         |                   |          |                                  |                       |                                |          |          |        |

\* = Test not applicable to this product.

## PART 3

|  |              |
|--|--------------|
| <b>CONTENTS OF THIS PART</b>                                     | <b>61</b>    |
| <b>V. Product information and recommendations.</b>               | <b>62-75</b> |
| Section 1 Characteristics concerning the woven material.         | 63           |
| Section 1 Characteristics concerning the knitted material.       | 64           |
| Section 2 Characteristics concerning the fabric and the garment: |              |
| 2.1 Trousers and shorts.   | 65           |
| 2.2 Skirts.  | 66           |
| 2.3 Jackets.   | 67           |
| 2.4 Coats.   | 68           |
| 2.5 Knitwear.  | 69           |
| 2.6 Anoraks, skiwear and sportswear.                             | 70           |
| 2.7 Pyjamas and nightwear.                                       | 71           |
| 2.8 Shirts, dresses and blouses.                                 | 72           |
| 2.9 Lingerie.  | 73           |
| 2.10 Swimwear.   | 74           |
| 2.11 Lining.   | 75           |

## V. PRODUCT INFORMATION AND RECOMMENDATIONS

**1.0 Clothing Enterprises may ask to their Suppliers supplementary information concerning characteristics not mentioned in PART 1 and PART 2 of this document.**

**The following information could be considered:**

- |      |   |   |
|------|---|---|
| 1.1  | <b>Kind of fibre</b>                                    | Relevant to artificial and synthetic fibres   |
|      | Supplier's information :                                | Spun fibre or filament  |
| 1.2  | <b>Optically brightened</b>                             |   |
|      | Supplier's information :                                | If finishing chemical was used  |
| 1.3  | <b>Fusibility</b>                                       |   |
|      | Supplier's information :                                | Fusing instructions and resin specifications<br>Concerning dimensional stability if it is over 1%<br>warp and weft, due to fusing press effects |
| 1.4  | <b>Permanent pleatability</b>                           | Supplier's information : If finishing chemical was<br>sed and make up instructions  |
| 1.5  | <b>Antistatic</b>                                       |   |
|      | Supplier's information :                                | If finishing chemical was used  |
| 1.6  | <b>Water repellent / Waterproof</b>                     |   |
|      | Supplier's information :                                | If finishing chemical was used  |
| 1.7  | <b>Other special finishing</b>                          |   |
|      | Supplier's information :                                | If finishing chemical was used  |
| 1.8  | <b>Napped goods / direction of design or finish</b>     |   |
|      | Supplier's information :                                | If there is one of these aspects  |
| 1.9  | <b>Length of repeat / panel print</b>                   |   |
|      | Supplier's information :                                | Length in cm  |
| 1.10 | <b>Width of repeat / panel print / stripe</b>           |   |
|      | Supplier's information :                                | Width in cm   |
| 1.11 | <b>Width of printed borders</b>                         |   |
|      | Supplier's information :                                | Width in cm at right and left   |
| 1.12 | <b>Printed borders of constant width</b>                |   |
|      | Supplier's information :                                | The border width is constant  |
| 1.13 | <b>Conformity with compulsory specifications of IWS</b> |   |
|      | Supplier's information :                                | The product conforms to Woolmark specification.<br>Licence No.  |
| 1.14 | <b>Additional manufacturing information</b>             |   |
|      | Supplier's information :                                | There are additional manufacturing information  |
| 1.15 | <b>Care labelling</b>                                   |   |
|      | Supplier's information :                                | Care labelling of the product instructions.   |

**2.0 In the following pages (from 54 to 66) examples of documents which can be used to exchange product information can be found. These documents do not pretend to be exhaustive. They are subject to change according to developments in the technical and legal area.**

|                        |                              |                         |
|------------------------|------------------------------|-------------------------|
| <b>PRODUCT INFO</b>    | Supplier:.....               | Internal article no. :  |
|                        | Supplier No.:.....           | Supplier's article no.: |
| <b>EURATEX TCG</b>     | Postal Code / Location:..... | Season:.....            |
|                        | Street:.....                 | Date:.....              |
| <b>RECOMMENDATIONS</b> | Contact person:.....         | Product line:.....      |
|                        | Tel:.....                    | End use.....            |
|                        | Fax:.....                    |                         |
|                        | E-mail:.....                 |                         |
| Date:.....             |                              |                         |

**SECTION 1.0 CHARACTERISTICS CONCERNING THE WOVEN MATERIAL.**

|  |               |           |
|--|---------------|-----------|
| Fabric Group   | Product Group | Reference |
| Refer also to section 2.0: CHARACTERISTICS CONCERNING THE FABRIC AND THE GARMENT |               |           |

| CHARACTERISTICS CONCERNING THE MATERIAL  | STANDARD REQUIREMENT ECLA RECOMMENDATION  | SUPPLIER'S DATA  |
|--|---|--|
| <b>1.1 CONSTRUCTION CHARACTERISTICS</b><br><input type="checkbox"/> Material composition according to Directive 96/73/EC and 96/74/EC of 16-12-1996, Directive 97/37/EC of 19-07-1997 and Directive 2004/34/EC of 23-03-2004.<br><input type="checkbox"/> Fabric name.....<br><input type="checkbox"/> Kind of fibre.....<br><input type="checkbox"/> Weight (Mass / m <sup>2</sup> ) EN 12127.....<br><input type="checkbox"/> Piece presentation.....<br><br><input type="checkbox"/> Average length of piece.....<br><input type="checkbox"/> Minimum usable width (excl. selvages).....<br><input type="checkbox"/> Number of fabric faults.....<br><br>THE FAULT MUST BE STRUNG | <br><br><br><br>+ / - 5%.....<br><br><br><br><br>- 0 cm / + 4 cm.....<br>to be negotiated between textile and apparel industry dependent on material, quality standard and price. | <br><br><br><br><input type="checkbox"/> spun fibre<br><input type="checkbox"/> filament fibre<br>.....grams / m <sup>2</sup><br><input type="checkbox"/> rolled<br><input type="checkbox"/> tabled<br><input type="checkbox"/> doubled<br>.....meters<br><br><br><br>.....cm  |
| <b>1.2 FINISH CHARACTERISTICS</b><br><input type="checkbox"/> Optically brightened.....<br><input type="checkbox"/> Fusibility.....<br><input type="checkbox"/> Permanent pleatability.....<br><input type="checkbox"/> Antistatic finish.....<br><input type="checkbox"/> Water-repellent / Waterproof ness.....<br><input type="checkbox"/> Other special finishes.....  | <br><br><br><br><br><br>  | <input type="checkbox"/> Yes <input type="checkbox"/> No<br>Explanation required<br><input type="checkbox"/> Yes <input type="checkbox"/> No<br><input type="checkbox"/> Yes <input type="checkbox"/> No<br><input type="checkbox"/> Yes <input type="checkbox"/> No<br><input type="checkbox"/> Yes <input type="checkbox"/> No |
| <b>1.3 PROCESSING CHARACTERISTICS</b><br><input type="checkbox"/> Napped goods /direction of design / finish.....<br><input type="checkbox"/> Length of repeat / panel print.....<br><input type="checkbox"/> Width of repeat / panel print / stripe.....<br><input type="checkbox"/> Width of printed borders.....<br><input type="checkbox"/> Printed borders of constant width.....<br><input type="checkbox"/> Skew.....   | <br><br><br><br><br>  | <input type="checkbox"/> Yes <input type="checkbox"/> No<br>.....cm<br>.....cm<br>Right....cm    Left .. cm<br><input type="checkbox"/> Yes <input type="checkbox"/> No  |
| <b>1.4 COLOUR CONTROL</b><br><input type="checkbox"/> TL 83/84, D65, A.<br><input type="checkbox"/> Colorimetric assessment  | Recommended lamps   | Supplier's lamps   |
| <b>1.5 CONFORMITY WITH COMPULSORY WOOLMARK SPECIFICATIONS</b>  | License nr.....   | <input type="checkbox"/> Yes <input type="checkbox"/> No   |

|                        |                              |                            |
|------------------------|------------------------------|----------------------------|
| <b>PRODUCT INFO</b>    | Supplier:.....               | Internal article no.....   |
|                        | Supplier No.:.....           | Supplier's article no..... |
| <b>EURATEX TCG</b>     | Postal Code / Location:..... | Season:.....               |
|                        | Street:.....                 | Date:.....                 |
| <b>RECOMMENDATIONS</b> | Contact person:.....         | Product line:.....         |
|                        | Tel:.....                    | End use.....               |
|                        | Fax:.....                    |                            |
|                        | E-mail:.....                 |                            |
| Date:.....             |                              |                            |

**SECTION 1.0 CHARACTERISTICS CONCERNING THE KNITTED MATERIAL.**

| Fabric Group   | Product Group | Reference |
|--|---------------|-----------|
| Refer also to section 2.0: CHARACTERISTICS CONCERNING THE FABRIC AND THE GARMENT |               |           |

| CHARACTERISTICS CONCERNING THE MATERIAL  | STANDARD REQUIREMENT ECLA RECOMMENDATION  | SUPPLIER'S DATA  |
|--|---|--|
| <b>1.1 CONSTRUCTION CHARACTERISTICS</b><br><input type="checkbox"/> Material composition according to Directive 96/73/EC and 96/74/EC of 16-12-1996, Directive 97/37/EC of 19-07-1997 and Directive 2004/34/EC of 23-03-2004.<br><input type="checkbox"/> Fabric name.....<br><input type="checkbox"/> Kind of fibre.....<br><input type="checkbox"/> Weight (Mass / m <sup>2</sup> ) EN 12127.....<br><input type="checkbox"/> Piece presentation.....<br><br><input type="checkbox"/> Average length of piece.....<br><input type="checkbox"/> Minimum usable width (excl. selvages).....<br><input type="checkbox"/> Number of fabric faults.....<br><br>THE FAULT MUST BE STRUNG | <br><br><br>+ / - 5%.....<br><br><br><br><br><br>- 0 cm / + 4 cm.....<br><br>to be negotiated between textile and apparel industry dependent on material, quality standard and price. | <br><br><br><br><input type="checkbox"/> spun fibre<br><input type="checkbox"/> filament fibre<br>.....grams / m <sup>2</sup><br><input type="checkbox"/> rolled<br><input type="checkbox"/> tabled<br><input type="checkbox"/> doubled<br>.....meters<br><br>.....cm  |
| <b>1.2 FINISH CHARACTERISTICS</b><br><input type="checkbox"/> Optically brightened.....<br><input type="checkbox"/> Fusibility.....<br><input type="checkbox"/> Permanent pleatability.....<br><input type="checkbox"/> Antistatic finish.....<br><input type="checkbox"/> Water-repellent / Waterproof ness.....<br><input type="checkbox"/> Other special finishes.....  | <br><br><br><br><br><br>  | <input type="checkbox"/> Yes <input type="checkbox"/> No<br>Explanation required<br><input type="checkbox"/> Yes <input type="checkbox"/> No<br><input type="checkbox"/> Yes <input type="checkbox"/> No<br><input type="checkbox"/> Yes <input type="checkbox"/> No<br><input type="checkbox"/> Yes <input type="checkbox"/> No |
| <b>1.3 PROCESSING CHARACTERISTICS</b><br><input type="checkbox"/> Napped goods /direction of design / finish.....<br><input type="checkbox"/> Length of repeat / panel print.....<br><input type="checkbox"/> Width of repeat / panel print / stripe.....<br><input type="checkbox"/> Width of printed borders.....<br><input type="checkbox"/> Printed borders of constant width.....<br><input type="checkbox"/> Skew.....   | <br><br><br><br><br>  | <input type="checkbox"/> Yes <input type="checkbox"/> No<br>.....cm<br>.....cm<br>Right...cm    Left ..cm<br><input type="checkbox"/> Yes <input type="checkbox"/> No  |
| <b>1.4 COLOUR CONTROL</b><br><input type="checkbox"/> TL 83/84, D65, A.<br><input type="checkbox"/> Colorimetric assessment  | Recommended lamps<br>.....  | Supplier's lamps<br>.....  |
| <b>1.5 CONFORMITY WITH COMPULSORY WOOLMARK SPECIFICATIONS</b>  | License nr.....   | <input type="checkbox"/> Yes <input type="checkbox"/> No   |



**SECTION 2.1: CHARACTERISTICS CONCERNING THE FABRIC AND THE GARMENT: TROUSERS AND SHORTS**

| CHARACTERISTICS  | STANDARD                   | STANDARD REQUIREMENT EURATEX TCG RECOMMENDATION |  | SUPPLIER'S VALUES OR TEST RESULTS |                 | Pass Fail |
|--|----------------------------|---|--|-----------------------------------|-----------------|-----------|
| <b>2.1 CARE LABELLING</b>  |                            |   |  |                                   |                 |           |
| Washing  | EN-ISO 3758                |   |  |                                   |                 |           |
| Bleaching  |                            |   |  |                                   |                 |           |
| Drying   |                            |   |  |                                   |                 |           |
| Ironing  |                            |   |  |                                   |                 |           |
| Dry cleaning   |                            |   |  |                                   |                 |           |
| <b>2.2 DIMENSIONAL STABILITY</b>   |                            | <b>Length</b>                                   | <b>Width</b>   | <b>Length</b>                     | <b>Width</b>    |           |
| <input type="checkbox"/> Steaming (pressing machine)                                       | DIN 52894 P2               | +/-1,0%   | -2,0%  | %                                 | %               |           |
| <input type="checkbox"/> Fusing (fusing press)   | DIN 54311                  | -1,5%   | -1,5%  | %                                 | %               |           |
| <input type="checkbox"/> Washing / drying (as indicated by the care label)*                | ISO 5077                   | -2,0%   | -2,0%  | %                                 | %               |           |
| <input type="checkbox"/> Dry cleaning  | EN-ISO 6330<br>EN-ISO 3175 | -1,5%   | -1,5%  | %                                 | %               |           |
| <b>2.3 MECHANICAL AND PHYSICAL PROPERTIES **</b>   |                            | <b>Full fit</b>                                 | <b>Tight fit</b>   |                                   |                 |           |
| <input type="checkbox"/> Breaking strength and Elongation in %                             | EN-ISO 13934-1             | 25 daN<br>12,5-55                               | 30 daN<br>12,5-55  | daN                               | daN             |           |
| <input type="checkbox"/> Breaking strength (Grab)  | EN-ISO 13934-2             | 18 daN  | 20 daN   | daN                               | daN             |           |
| <input type="checkbox"/> Tear strength   | EN-ISO 13937-1             | 1,5 daN   | 1,6 daN  | daN                               | daN             |           |
| <input type="checkbox"/> Seam slippage: <b>mm at daN</b>                                   | EN-ISO 13936-1             | 4 at 14   | 4 at 16  | 4 at .....                        | 4 at .....      |           |
| <input type="checkbox"/> Seam slippage: <b>daN at mm</b>                                   | EN-ISO 13936-2             | 12 at 3   | 12 at 2  | 12 at .....                       | 12 at .....     |           |
| <input type="checkbox"/> Abrasion resistance (9kPa)  | EN-ISO 12947-2             | 20.000 revs***                                  |  | revs                              |                 |           |
| <input type="checkbox"/> Crease recovery   | ISO 2313                   | 110°-120°                                       |  | °                                 |                 |           |
| <input type="checkbox"/> Crease recovery   | ISO 9867                   | 4   |  |                                   |                 |           |
| <input type="checkbox"/> Pilling<br>FS= Flat surface<br>RS= Raised surface<br>Kn= Knitwear | EN-ISO 12945-2             | 125 revs<br>500 revs<br>1000 revs<br>2000 revs  | FS 4, RS 3-4, Kn 3-4<br>FS 4, RS 3, Kn 3<br>FS 4, RS 2-3, Kn 2-3<br>FS 4 |                                   |                 |           |
| <b>2.4 COLOUR FASTNESS ****</b>  | EN-ISO 105 A01-A03         | <b>Change</b>                                   | <b>Staining</b>  | <b>Change</b>                     | <b>Staining</b> |           |
| <input type="checkbox"/> to washing  | EN-ISO 105 C06, C08, C09   | 4   | 4  |                                   |                 |           |
| <input type="checkbox"/> to dry cleaning   | EN-ISO 105 D01             | 4   | -  |                                   |                 |           |
| <input type="checkbox"/> to ironing  | EN-ISO 105 X12             | 4   | 4  |                                   |                 |           |
| <input type="checkbox"/> to light, weathering  | EN-ISO 105 B02, B04        | 5   | -  |                                   |                 |           |
| <input type="checkbox"/> to perspiration, acid   | EN-ISO 105 E04             | 4   | 4  |                                   |                 |           |
| <input type="checkbox"/> to perspiration, alkaline   |                            | 4   | 4  |                                   |                 |           |
| <input type="checkbox"/> to rubbing , dry  | EN-ISO 105 X12             | -   | 4  |                                   |                 |           |
| <input type="checkbox"/> to rubbing , wet  |                            | -   | 3-4  |                                   |                 |           |
| <input type="checkbox"/> to water  | EN-ISO 105 E01             | 4   | 4  |                                   |                 |           |
| <b>2.5 OTHER CHARACTERISTICS</b>   |                            |   |  |                                   |                 |           |
| <input type="checkbox"/> Other   |                            |   |  |                                   |                 |           |
| <input type="checkbox"/> Other tests are not considered                                    |                            |   |  |                                   |                 |           |

\* For fabrics containing elastane special consultation is recommended.

\*\* For trousers in suits lower values are applicable, see JACKETS.

\*\*\* Corduroy abrasion backside: 9kPa, 5.000 revs.

\*\*\*\* Garments with contrast colours: colour fastness to washing, perspiration and water: staining 4-5. Colour fastness to rubbing of corduroy, denim and heavy shades: dry 3, wet 2.

## SECTION 2.2: CHARACTERISTICS CONCERNING THE FABRIC AND THE GARMENT: SKIRTS

| CHARACTERISTICS  | STANDARD                   | STANDARD REQUIREMENT EURATEX TCG RECOMMENDATION |  | SUPPLIER'S VALUES OR TEST RESULTS |                 | Pass Fail |
|--|----------------------------|---|--|-----------------------------------|-----------------|-----------|
| <b>2.1 CARE LABELLING</b>  |                            |   |  |                                   |                 |           |
| Washing  | EN-ISO 3758                |   |  |                                   |                 |           |
| Bleaching  |                            |   |  |                                   |                 |           |
| Drying   |                            |   |  |                                   |                 |           |
| Ironing  |                            |   |  |                                   |                 |           |
| Dry cleaning   |                            |   |  |                                   |                 |           |
| <b>2.2 DIMENSIONAL STABILITY</b>   |                            | <b>Length</b>                                   | <b>Width</b>   | <b>Length</b>                     | <b>Width</b>    |           |
| <input type="checkbox"/> Steaming (pressing machine)                                       | DIN 52894 P2               | +/-1,0%   | -2,0%  | %                                 | %               |           |
| <input type="checkbox"/> Fusing (fusing press)   | DIN 54311                  | -1,5%   | -1,5%  | %                                 | %               |           |
| <input type="checkbox"/> Washing / drying (as indicated by the care label)*                | ISO 5077                   | -2,0%   | -2,0%  | %                                 | %               |           |
| <input type="checkbox"/> Dry cleaning  | EN-ISO 6330<br>EN-ISO 3175 | -1,5%   | -1,5%  | %                                 | %               |           |
| <b>2.3 MECHANICAL AND PHYSICAL PROPERTIES</b>  |                            | <b>Full fit</b>                                 | <b>Tight fit</b>   |                                   |                 |           |
| <input type="checkbox"/> Breaking strength and Elongation in %                             | EN-ISO 13934-1             | 25 daN<br>12,5-55                               | 30 daN<br>12,5-55  | daN                               | daN             |           |
| <input type="checkbox"/> Breaking strength (Grab)  | EN-ISO 13934-2             | 18 daN  | 20 daN   | daN                               | daN             |           |
| <input type="checkbox"/> Tear strength   | EN-ISO 13937-1             | 1,5 daN   | 1,6 daN  | daN                               | daN             |           |
| <input type="checkbox"/> Seam slippage: <b>mm at daN</b>                                   | EN-ISO 13936-1             | 4 at 14   | 4 at 16  | 4 at .....                        | 4 at .....      |           |
| <input type="checkbox"/> Seam slippage: <b>daN at mm</b>                                   | EN-ISO 13936-2             | 12 at 3   | 12 at 2  | 12 at ....                        | 12 at ....      |           |
| <input type="checkbox"/> Abrasion resistance (9kPa)  | EN-ISO 12947-2             | 20.000 revs**                                   |  | revs                              |                 |           |
| <input type="checkbox"/> Crease recovery   | ISO 2313                   | 110°-120°                                       |  | °                                 |                 |           |
| <input type="checkbox"/> Crease recovery   | ISO 9867                   | 4   |  |                                   |                 |           |
| <input type="checkbox"/> Pilling<br>FS= Flat surface<br>RS= Raised surface<br>Kn= Knitwear | EN-ISO 12945-2             | 125 revs<br>500 revs<br>1000 revs<br>2000 revs  | FS 4, RS 3-4, Kn 3-4<br>FS 4, RS 3, Kn 3<br>FS 4, RS 2-3, Kn 2-3<br>FS 4 |                                   |                 |           |
| <b>2.4 COLOUR FASTNESS ***</b>   | EN-ISO 105 A01-A03         | <b>Change</b>                                   | <b>Staining</b>  | <b>Change</b>                     | <b>Staining</b> |           |
| <input type="checkbox"/> to washing  | EN-ISO 105 C06, C08, C09   | 4   | 4  |                                   |                 |           |
| <input type="checkbox"/> to dry cleaning   | EN-ISO 105 D01             | 4   | -  |                                   |                 |           |
| <input type="checkbox"/> to ironing  | EN-ISO 105 X12             | 4   | 4  |                                   |                 |           |
| <input type="checkbox"/> to light, weathering  | EN-ISO 105 B02, B04        | 5   | -  |                                   |                 |           |
| <input type="checkbox"/> to perspiration, acid   | EN-ISO 105 E04             | 4   | 4  |                                   |                 |           |
| <input type="checkbox"/> to perspiration, alkaline   |                            | 4   | 4  |                                   |                 |           |
| <input type="checkbox"/> to rubbing , dry  | EN-ISO 105 X12             | -   | 4  |                                   |                 |           |
| <input type="checkbox"/> to rubbing , wet  |                            | -   | 3-4  |                                   |                 |           |
| <input type="checkbox"/> to water  | EN-ISO 105 E01             | 4   | 4  |                                   |                 |           |
| <b>2.5 OTHER CHARACTERISTICS</b>   |                            |   |  |                                   |                 |           |
| <input type="checkbox"/> Other   |                            |   |  |                                   |                 |           |
| <input type="checkbox"/> Other tests are not considered                                    |                            |   |  |                                   |                 |           |

\* For fabrics containing elastane special consultation is recommended.

\*\* Corduroy abrasion backside: 9kPa, 5.000 revs.

\*\*\* Garments with contrast colours: colour fastness to washing, perspiration and water: staining 4-5. Colour fastness to rubbing of corduroy, denim and heavy shades: dry 3, wet 2.

**SECTION 2.3: CHARACTERISTICS CONCERNING THE FABRIC AND THE GARMENT: JACKETS**

| CHARACTERISTICS  | STANDARD            | STANDARD REQUIREMENT EURATEX TCG RECOMMENDATION |  | SUPPLIER'S VALUES OR TEST RESULTS |                 | Pass Fail |
|--|---------------------|---|--|-----------------------------------|-----------------|-----------|
| <b>2.1 CARE LABELLING</b><br>Washing<br>Bleaching<br>Drying<br>Ironing<br>Dry cleaning     | EN-ISO 3758         |   |  |                                   |                 |           |
| <b>2.2 DIMENSIONAL STABILITY</b>   |                     | <b>Length</b>                                   | <b>Width</b>   | <b>Length</b>                     | <b>Width</b>    |           |
| <input type="checkbox"/> Steaming (pressing machine)                                       | DIN 52894 P2        | +/-1,0%   | -2,0%  | %                                 | %               |           |
| <input type="checkbox"/> Fusing (fusing press)   | DIN 54311           | -1,5%   | -1,5%  | %                                 | %               |           |
| <input type="checkbox"/> Dry cleaning  | EN-ISO 3175         | -1,5%   | -1,5%  | %                                 | %               |           |
| <b>2.3 MECHANICAL AND PHYSICAL PROPERTIES *</b>  |                     | <b>Full fit</b>                                 | <b>Tight fit</b>   |                                   |                 |           |
| <input type="checkbox"/> Breaking strength and Elongation in %                             | EN-ISO 13934-1      | 20 daN<br>12,5-40                               | 20 daN<br>12,5-40  | daN                               | daN             |           |
| <input type="checkbox"/> Breaking strength (Grab)  | EN-ISO 13934-2      | 15 daN  | 15 daN   | daN                               | daN             |           |
| <input type="checkbox"/> Tear strength   | EN-ISO 13937-1      | 1,2 daN   | 1,2 daN  | daN                               | daN             |           |
| <input type="checkbox"/> Seam slippage: <b>mm at daN</b>                                   | EN-ISO 13936-1      | 4 at 12   | 4 at 12  | 4 at .....                        | 4 at .....      |           |
| <input type="checkbox"/> Seam slippage: <b>daN at mm</b>                                   | EN-ISO 13936-2      | 12 at 4   | 12 at 3  | 12 at ....                        | 12 at ....      |           |
| <input type="checkbox"/> Abrasion resistance (9kPa)  | EN-ISO 12947-2      | 16.000 revs**                                   |  | revs                              |                 |           |
| <input type="checkbox"/> Crease recovery   | ISO 2313            | 110°-120°                                       |  | °                                 |                 |           |
| <input type="checkbox"/> Crease recovery   | ISO 9867            | 4   |  |                                   |                 |           |
| <input type="checkbox"/> Pilling<br>FS= Flat surface<br>RS= Raised surface<br>Kn= Knitwear | EN-ISO 12945-2      | 125 revs<br>500 revs<br>1000 revs<br>2000 revs  | FS 4, RS 3-4, Kn 3-4<br>FS 4, RS 3, Kn 3<br>FS 4, RS 2-3, Kn 2-3<br>FS 4 |                                   |                 |           |
| <b>2.4 COLOUR FASTNESS ***</b>   | EN-ISO 105 A01-A03  | <b>Change</b>                                   | <b>Staining</b>  | <b>Change</b>                     | <b>Staining</b> |           |
| <input type="checkbox"/> to dry cleaning   | EN-ISO 105 D01      | 4   | -  |                                   |                 |           |
| <input type="checkbox"/> to ironing  | EN-ISO 105 X12      | 4   | 4  |                                   |                 |           |
| <input type="checkbox"/> to light, weathering  | EN-ISO 105 B02, B04 | 5   | -  |                                   |                 |           |
| <input type="checkbox"/> to perspiration, acid   | EN-ISO 105 E04      | 4   | 4  |                                   |                 |           |
| <input type="checkbox"/> to perspiration, alkaline   |                     | 4   | 4  |                                   |                 |           |
| <input type="checkbox"/> to rubbing , dry  | EN-ISO 105 X12      | -   | 4  |                                   |                 |           |
| <input type="checkbox"/> to rubbing , wet  |                     | -   | 3-4  |                                   |                 |           |
| <input type="checkbox"/> to water  | EN-ISO 105 E01      | 4   | 4  |                                   |                 |           |
| <b>2.5 OTHER CHARACTERISTICS</b>   |                     |   |  |                                   |                 |           |
| <input type="checkbox"/> Other   |                     |   |  |                                   |                 |           |
| <input type="checkbox"/> Other tests are not considered                                    |                     |   |  |                                   |                 |           |

\* For lightweight suits lower values may be considered.

\*\* Corduroy abrasion backside: 9kPa, 5.000 revs.

\*\*\* Garments with contrast colours: colour fastness to perspiration: staining 4-5.

Colour fastness to rubbing of corduroy, denim and heavy shades: dry 3, wet 2.

**SECTION 2.4: CHARACTERISTICS CONCERNING THE FABRIC AND THE GARMENT: COATS**

| CHARACTERISTICS  | STANDARD                   | STANDARD REQUIREMENT EURATEX TCG RECOMMENDATION |                      | SUPPLIER'S VALUES OR TEST RESULTS |                 | Pass Fail |
|--|----------------------------|---|----------------------|-----------------------------------|-----------------|-----------|
| <b>2.1 CARE LABELLING</b>  |                            |   |                      |                                   |                 |           |
| Washing  | EN-ISO 3758                |   |                      |                                   |                 |           |
| Bleaching  |                            |   |                      |                                   |                 |           |
| Drying   |                            |   |                      |                                   |                 |           |
| Ironing  |                            |   |                      |                                   |                 |           |
| Dry cleaning   |                            |   |                      |                                   |                 |           |
| <b>2.2 DIMENSIONAL STABILITY</b>   |                            | <b>Length</b>                                   | <b>Width</b>         | <b>Length</b>                     | <b>Width</b>    |           |
| <input type="checkbox"/> Steaming (pressing machine)                                       | DIN 52894 P2               | +/-1,0%   | -2,0%                | %                                 | %               |           |
| <input type="checkbox"/> Fusing (fusing press)   | DIN 54311                  | -1,5%   | -1,5%                | %                                 | %               |           |
| <input type="checkbox"/> Washing / drying (as indicated by the care label)*                | ISO 5077                   | -2,0%   | -2,0%                | %                                 | %               |           |
| <input type="checkbox"/> Dry cleaning  | EN-ISO 6330<br>EN-ISO 3175 | -1,5%   | -1,5%                | %                                 | %               |           |
| <b>2.3 MECHANICAL AND PHYSICAL PROPERTIES</b>  |                            |   |                      |                                   |                 |           |
| <input type="checkbox"/> Breaking strength and Elongation in %                             | EN-ISO 13934-1             | 20 daN<br>12,5 - 55                             |                      | daN                               | daN             |           |
| <input type="checkbox"/> Breaking strength (Grab)  | EN-ISO 13934-2             | 15 daN  |                      | daN                               | daN             |           |
| <input type="checkbox"/> Seam slippage: <b>mm at daN</b>                                   | EN-ISO 13936-1             | 4 at 14   | 4 at 14              | 4 at .....                        | 4 at .....      |           |
| <input type="checkbox"/> Seam slippage: <b>daN at mm</b>                                   | EN-ISO 13936-2             | 12 at 4   | 12 at 3              | 12 at ....                        | 12 at ....      |           |
| <input type="checkbox"/> Tear strength   | EN-ISO 13937-1             | 1,2 daN   |                      | daN                               | daN             |           |
| <input type="checkbox"/> Abrasion resistance (9kPa)  | EN-ISO 12947-2             | 16.000 revs**                                   |                      | revs                              |                 |           |
| <input type="checkbox"/> Crease recovery   | ISO 2313                   | 110°-120°                                       |                      | °                                 |                 |           |
| <input type="checkbox"/> Crease recovery   | ISO 9867                   | 4   |                      |                                   |                 |           |
| <input type="checkbox"/> Pilling<br>FS= Flat surface<br>RS= Raised surface<br>Kn= Knitwear | EN-ISO 12945-2             | 125 revs  | FS 4, RS 3-4, Kn 3-4 |                                   |                 |           |
|  |                            | 500 revs  | FS 4, RS 3, Kn 3     |                                   |                 |           |
|  |                            | 1000 revs                                       | FS 4, RS 2-3, Kn 2-3 |                                   |                 |           |
|  |                            | 2000 revs                                       | FS 4                 |                                   |                 |           |
| <b>2.4 COLOUR FASTNESS ***</b>   | EN-ISO 105 A01-A03         | <b>Change</b>                                   | <b>Staining</b>      | <b>Change</b>                     | <b>Staining</b> |           |
| <input type="checkbox"/> to washing  | EN-ISO 105 C06, C08, C09   | 4   | 4                    |                                   |                 |           |
| <input type="checkbox"/> to dry cleaning   | EN-ISO 105 D01             | 4   | -                    |                                   |                 |           |
| <input type="checkbox"/> to ironing  | EN-ISO 105 X12             | 4   | 4                    |                                   |                 |           |
| <input type="checkbox"/> to light, weathering  | EN-ISO 105 B02, B04        | 5   | -                    |                                   |                 |           |
| <input type="checkbox"/> to perspiration, acid   | EN-ISO 105 E04             | 4   | 4                    |                                   |                 |           |
| <input type="checkbox"/> to perspiration, alkaline   |                            | 4   | 4                    |                                   |                 |           |
| <input type="checkbox"/> to rubbing , dry  | EN-ISO 105 X12             | -   | 4                    |                                   |                 |           |
| <input type="checkbox"/> to rubbing , wet  |                            | -   | 3-4                  |                                   |                 |           |
| <input type="checkbox"/> to water  | EN-ISO 105 E01             | 4   | 4                    |                                   |                 |           |
| <b>2.5 OTHER CHARACTERISTICS</b>   |                            |   |                      |                                   |                 |           |
| <input type="checkbox"/> Other   |                            |   |                      |                                   |                 |           |
| <input type="checkbox"/> Other tests are not considered                                    |                            |   |                      |                                   |                 |           |

\* For fabrics containing elastane special consultation is recommended.

\*\* Corduroy abrasion backside: 9kPa, 5.000 revs.

\*\*\* Garments with contrast colours: colour fastness to washing, perspiration and water: staining 4-5. Colour fastness to rubbing of corduroy, denim and heavy shades: dry 3, wet 2.

**SECTION 2.5: CHARACTERISTICS CONCERNING THE FABRIC AND THE GARMENT: KNITWEAR**

| CHARACTERISTICS   | STANDARD                   | STANDARD REQUIREMENT EURATEX TCG RECOMMENDATION |                 | SUPPLIER'S VALUES OR TEST RESULTS |                 | Pass Fail |
|---|----------------------------|---|-----------------|-----------------------------------|-----------------|-----------|
| <b>2.1 CARE LABELLING</b>   |                            |   |                 |                                   |                 |           |
| Washing   | EN-ISO 3758                |   |                 |                                   |                 |           |
| Bleaching   |                            |   |                 |                                   |                 |           |
| Drying  |                            |   |                 |                                   |                 |           |
| Ironing   |                            |   |                 |                                   |                 |           |
| Dry cleaning  |                            |   |                 |                                   |                 |           |
|   |                            |   |                 |                                   |                 |           |
| <b>2.2 DIMENSIONAL STABILITY</b>  |                            | <b>Length</b>                                   | <b>Width</b>    | <b>Length</b>                     | <b>Width</b>    |           |
| <input type="checkbox"/> Steaming (pressing machine)                        | DIN 52894 P2               | -3,0%   | -3,0%           | %                                 | %               |           |
| <input type="checkbox"/> Fusing (fusing press)                              | DIN 54311                  | -3,0%   | -3,0%           | %                                 | %               |           |
| <input type="checkbox"/> Washing / drying (as indicated by the care label)* | ISO 5077                   | -6%/+2%   | -6%/+2%         | %                                 | %               |           |
| <input type="checkbox"/> Dry cleaning                                       | EN-ISO 6330<br>EN-ISO 3175 | -2,5%   | -2,5%           | %                                 | %               |           |
| <b>2.3 MECHANICAL AND PHYSICAL PROPERTIES</b>                               |                            |   |                 |                                   |                 |           |
| <input type="checkbox"/> Bursting strength                                  | EN-ISO 13938-2             | 200 kPa, (7,3 cm <sup>2</sup> )                 |                 |                                   |                 |           |
| <input type="checkbox"/> Abrasion resistance (9kPa)                         | EN-ISO 12947-2             | 8.000 revs                                      |                 | revs                              |                 |           |
| <input type="checkbox"/> Pilling  | EN-ISO 12945-2             | 125 revs: 3-4                                   |                 |                                   |                 |           |
|   |                            | 500 revs: 3                                     |                 |                                   |                 |           |
|   |                            | 1000 revs: 2-3                                  |                 |                                   |                 |           |
| <b>2.4 COLOUR FASTNESS **</b>   | ISO 105 A01-A03            | <b>Change</b>                                   | <b>Staining</b> | <b>Change</b>                     | <b>Staining</b> |           |
| <input type="checkbox"/> to washing   | EN-ISO 105 C06, C08, C09   | 4   | 4               |                                   |                 |           |
| <input type="checkbox"/> to dry cleaning                                    | EN-ISO 105 D01             | 4   | -               |                                   |                 |           |
| <input type="checkbox"/> to ironing   | EN-ISO 105 X12             | 4   | 4               |                                   |                 |           |
| <input type="checkbox"/> to light, weathering                               | EN-ISO 105 B02, B04        | 5   | -               |                                   |                 |           |
| <input type="checkbox"/> to perspiration, acid                              | EN-ISO 105 E04             | 4   | 4               |                                   |                 |           |
| <input type="checkbox"/> to perspiration, alkaline                          |                            | 4   | 4               |                                   |                 |           |
| <input type="checkbox"/> to rubbing , dry                                   | EN-ISO 105 X12             | -   | 4               |                                   |                 |           |
| <input type="checkbox"/> to rubbing , wet                                   |                            | -   | 3-4             |                                   |                 |           |
| <input type="checkbox"/> to water   | EN-ISO 105 E01             | 4   | 4               |                                   |                 |           |
| <b>2.5 OTHER CHARACTERISTICS</b>  |                            |   |                 |                                   |                 |           |
| <input type="checkbox"/> Other  |                            |   |                 |                                   |                 |           |
| <input type="checkbox"/> Other tests are not considered                     |                            |   |                 |                                   |                 |           |

\* For fabrics containing elastane special consultation is recommended.

\*\* Garments with contrast colours: colour fastness to washing, perspiration and water: staining 4-5. Colour fastness to rubbing of heavy shades: dry 3, wet 2.

**SECTION 2.6: CHARACTERISTICS CONCERNING THE FABRIC AND THE GARMENT: ANORAKS,  
SKIWEAR AND SPORTSWEAR**

| CHARACTERISTICS  | STANDARD                   | STANDARD REQUIREMENT EURATEX TCG RECOMMENDATION |                      | SUPPLIER'S VALUES OR TEST RESULTS |                 | Pass<br>Fail |
|--|----------------------------|---|----------------------|-----------------------------------|-----------------|--------------|
| <b>2.1 CARE LABELLING</b>  |                            |   |                      |                                   |                 |              |
| Washing  | EN-ISO 3758                |   |                      |                                   |                 |              |
| Bleaching  |                            |   |                      |                                   |                 |              |
| Drying   |                            |   |                      |                                   |                 |              |
| Ironing  |                            |   |                      |                                   |                 |              |
| Dry cleaning   |                            |   |                      |                                   |                 |              |
| <b>2.2 DIMENSIONAL STABILITY</b>   |                            | <b>Length</b>                                   | <b>Width</b>         | <b>Length</b>                     | <b>Width</b>    |              |
| <input type="checkbox"/> Steaming (pressing machine)                                       | DIN 52894 P2               | +/-1,0%   | -2,0%                | %                                 | %               |              |
| <input type="checkbox"/> Fusing (fusing press)   | DIN 54311                  | -1,5%   | -1,5%                | %                                 | %               |              |
| <input type="checkbox"/> Washing / drying (as indicated by the care label)*                | ISO 5077                   | -3,0%   | -3,0%                | %                                 | %               |              |
| <input type="checkbox"/> Dry cleaning  | EN-ISO 6330<br>EN-ISO 3175 | -1,5%   | -1,5%                | %                                 | %               |              |
| <b>2.3 MECHANICAL AND PHYSICAL PROPERTIES</b>  |                            |   |                      |                                   |                 |              |
| <input type="checkbox"/> Breaking strength and Elongation in %                             | EN-ISO 13934-1             | 25 daN<br>12,5 - 55                             |                      | daN                               | daN             |              |
| <input type="checkbox"/> Breaking strength (Grab)  | EN-ISO 13934-2             | 18 daN  |                      | daN                               | daN             |              |
| <input type="checkbox"/> Tear strength   | EN-ISO 13937-1             | 1,2 daN   |                      | daN                               | daN             |              |
| <input type="checkbox"/> Seam slippage: <b>mm at daN</b>                                   | EN-ISO 13936-1             | 4 at 14   | 4 at 14              | 4 at .....                        | 4 at .....      |              |
| <input type="checkbox"/> Seam slippage: <b>daN at mm</b>                                   | EN-ISO 13936-2             | 12 at 4   | 12 at 3              | 12 at ....                        | 12 at ....      |              |
| <input type="checkbox"/> Abrasion resistance (9kPa)  | EN-ISO 12947-2             | 16.000 revs                                     |                      | revs                              |                 |              |
| <input type="checkbox"/> Pilling<br>FS= Flat surface<br>RS= Raised surface<br>Kn= Knitwear | EN-ISO 12945-2             | 125 revs  | FS 4, RS 3-4, Kn 3-4 |                                   |                 |              |
|  |                            | 500 revs  | FS 4, RS 3, Kn 3     |                                   |                 |              |
|  |                            | 1000 revs                                       | FS 4, RS 2-3, Kn 2-3 |                                   |                 |              |
|  |                            | 2000 revs                                       | FS 4                 |                                   |                 |              |
| <b>2.4 COLOUR FASTNESS **</b>  | ISO 105 A01-A03            | <b>Change</b>                                   | <b>Staining</b>      | <b>Change</b>                     | <b>Staining</b> |              |
| <input type="checkbox"/> to washing  | EN-ISO 105 C06, C08, C09   | 4   | 4                    |                                   |                 |              |
| <input type="checkbox"/> to dry cleaning   | EN-ISO 105 D01             | 4   | -                    |                                   |                 |              |
| <input type="checkbox"/> to ironing  | EN-ISO 105 X12             | 4   | 4                    |                                   |                 |              |
| <input type="checkbox"/> to light, weathering  | EN-ISO 105 B02, B04        | 5   | -                    |                                   |                 |              |
| <input type="checkbox"/> to perspiration, acid   | EN-ISO 105 E04             | 4   | 4                    |                                   |                 |              |
| <input type="checkbox"/> to perspiration, alkaline   |                            | 4   | 4                    |                                   |                 |              |
| <input type="checkbox"/> to rubbing, dry   | EN-ISO 105 X12             | -   | 4                    |                                   |                 |              |
| <input type="checkbox"/> to rubbing, wet   |                            | -   | 3-4                  |                                   |                 |              |
| <input type="checkbox"/> to water  | EN-ISO 105 E01             | 4   | 4                    |                                   |                 |              |
| <b>2.5 OTHER CHARACTERISTICS</b>   |                            |   |                      |                                   |                 |              |
| <input type="checkbox"/> Other   |                            |   |                      |                                   |                 |              |
| <input type="checkbox"/> Other tests are not considered                                    |                            |   |                      |                                   |                 |              |

\* For fabrics containing elastane special consultation is recommended.

\*\* Garments with contrast colours: colour fastness to washing, perspiration and water: staining 4-5. Colour fastness to rubbing of corduroy, denim and heavy shades: dry 3, wet 2.

**SECTION 2.7: CHARACTERISTICS CONCERNING THE FABRIC AND THE GARMENT: PYJAMA'S AND NIGHTWEAR**

| CHARACTERISTICS   | STANDARD                   | STANDARD REQUIREMENT EURATEX TCG RECOMMENDATION |                      | SUPPLIER'S VALUES OR TEST RESULTS |                 | Pass Fail |
|---|----------------------------|---|----------------------|-----------------------------------|-----------------|-----------|
| <b>2.1 CARE LABELLING</b>   | EN-ISO 3758                |   |                      |                                   |                 |           |
| Washing   |                            |   |                      |                                   |                 |           |
| Bleaching   |                            |   |                      |                                   |                 |           |
| Drying  |                            |   |                      |                                   |                 |           |
| Ironing   |                            |   |                      |                                   |                 |           |
| Dry cleaning  |                            |   |                      |                                   |                 |           |
| <b>2.2 DIMENSIONAL STABILITY</b>  |                            | <b>Length</b>                                   | <b>Width</b>         | <b>Length</b>                     | <b>Width</b>    |           |
| <input type="checkbox"/> Steaming (pressing machine)                        | DIN 52894 P2               | +/-1,0%   | -2,0%                | %                                 | %               |           |
| <input type="checkbox"/> Fusing (fusing press)                              | DIN 54311                  | -1,5%   | -1,5%                | %                                 | %               |           |
| <input type="checkbox"/> Washing / drying (as indicated by the care label)* | ISO 5077                   | -2,0%   | -2,0%                | %                                 | %               |           |
| <input type="checkbox"/> Dry cleaning                                       | EN-ISO 6330<br>EN-ISO 3175 | -1,5%   | -1,5%                | %                                 | %               |           |
| <b>2.3 MECHANICAL AND PHYSICAL PROPERTIES</b>                               |                            | <b>Full fit</b>                                 | <b>Tight fit</b>     |                                   |                 |           |
| <input type="checkbox"/> Breaking strength and Elongation in %              | EN-ISO 13934-1             | 18 daN<br>12,5 - 40                             | 22 daN<br>12,5 -55   | daN                               | daN             |           |
| <input type="checkbox"/> Breaking strength (Grab)                           | EN-ISO 13934-2             | 12 daN  | 15 daN               | daN                               | daN             |           |
| <input type="checkbox"/> Tear strength                                      | EN-ISO 13937-1             | 0,8 daN   | 1,0                  | daN                               | daN             |           |
| <input type="checkbox"/> Seam slippage: <b>mm at daN</b>                    | EN-ISO 13936-1             | 4 at 10   | 4 at 12              | 4 at .....                        | 4 at .....      |           |
| <input type="checkbox"/> Seam slippage: <b>daN at mm</b>                    | EN-ISO 13936-2             | 6 at 3  | 6 at 2               | 6 at .....                        | 6 at .....      |           |
| <input type="checkbox"/> Bursting strength                                  | EN-ISO 13938-2             | 200 kPa, (7,3 cm <sup>2</sup> )                 |                      |                                   |                 |           |
| <input type="checkbox"/> Abrasion resistance (9kPa)                         | EN-ISO 12947-2             | 10.000 revs.                                    |                      | revs                              |                 |           |
| <input type="checkbox"/> Pilling  | EN-ISO 12945-2             | 125 revs  | FS 4, RS 3-4, Kn 3-4 |                                   |                 |           |
| <input type="checkbox"/> FS= Flat surface                                   |                            | 500 revs  | FS 4, RS 3, Kn 3     |                                   |                 |           |
| <input type="checkbox"/> RS= Raised surface                                 |                            | 1000 revs                                       | FS 4, RS 2-3, Kn 2-3 |                                   |                 |           |
| <input type="checkbox"/> Kn= Knitwear                                       |                            | 2000 revs                                       | FS 4                 |                                   |                 |           |
| <b>2.4 COLOUR FASTNESS **</b>   | EN-ISO 105 A01-A03         | <b>Change</b>                                   | <b>Staining</b>      | <b>Change</b>                     | <b>Staining</b> |           |
| <input type="checkbox"/> to washing   | EN-ISO 105 C06, C08, C09   | 4   | 4                    |                                   |                 |           |
| <input type="checkbox"/> to dry cleaning                                    | EN-ISO 105 D01             | 4   | -                    |                                   |                 |           |
| <input type="checkbox"/> to ironing   | EN-ISO 105 X12             | 4   | 4                    |                                   |                 |           |
| <input type="checkbox"/> to light, weathering                               | EN-ISO 105 B02, B04        | 4   | -                    |                                   |                 |           |
| <input type="checkbox"/> to perspiration, acid                              | EN-ISO 105 E04             | 4   | 4                    |                                   |                 |           |
| <input type="checkbox"/> to perspiration, alkaline                          |                            | 4   | 4                    |                                   |                 |           |
| <input type="checkbox"/> to rubbing, dry                                    | EN-ISO 105 X12             | -   | 4                    |                                   |                 |           |
| <input type="checkbox"/> to rubbing, wet                                    |                            | -   | 3-4                  |                                   |                 |           |
| <input type="checkbox"/> to water   | EN-ISO 105 E01             | 4   | 4                    |                                   |                 |           |
| <b>2.5 OTHER CHARACTERISTICS</b>  |                            |   |                      |                                   |                 |           |
| <input type="checkbox"/> Other  |                            |   |                      |                                   |                 |           |
| <input type="checkbox"/> Other tests are not considered                     |                            |   |                      |                                   |                 |           |

\* For fabrics containing elastane special consultation is recommended.

\* Weft knits: -6% / +2%

\*\* Garments with contrast colours: colour fastness to washing, perspiration and water: staining 4-5.

**SECTION 2.8: CHARACTERISTICS CONCERNING THE FABRIC AND THE GARMENT: SHIRTS, DRESSES AND BLOUSES**

| CHARACTERISTICS  | STANDARD                   | STANDARD REQUIREMENT<br>EURATEX TCG<br>RECOMMENDATION |                      | SUPPLIER'S<br>VALUES OR TEST<br>RESULTS |                 | Pass<br>Fail |
|--|----------------------------|---|----------------------|---|-----------------|--------------|
| <b>2.1 CARE LABELLING</b>  |                            |   |                      |   |                 |              |
| Washing  | EN-ISO 3758                |   |                      |   |                 |              |
| Bleaching  |                            |   |                      |   |                 |              |
| Drying   |                            |   |                      |   |                 |              |
| Ironing  |                            |   |                      |   |                 |              |
| Dry cleaning   |                            |   |                      |   |                 |              |
| <b>2.2 DIMENSIONAL STABILITY</b>   |                            | <b>Length</b>   | <b>Width</b>         | <b>Length</b>                           | <b>Width</b>    |              |
| <input type="checkbox"/> Steaming (pressing machine)                                       | DIN 52894 P2               | +/-1,0%   | -2,0%                | %                                       | %               |              |
| <input type="checkbox"/> Fusing (fusing press)   | DIN 54311                  | -1,5%   | -1,5%                | %                                       | %               |              |
| <input type="checkbox"/> Washing / drying (as indicated by the care label)*                | ISO 5077                   | -2,0%   | -2,0%                | %                                       | %               |              |
| <input type="checkbox"/> Dry cleaning  | EN-ISO 6330<br>EN-ISO 3175 | -1,5%   | -1,5%                | %                                       | %               |              |
| <b>2.3 MECHANICAL AND PHYSICAL PROPERTIES</b>  |                            | <b>Full fit</b>                                       | <b>Tight fit</b>     |   |                 |              |
| <input type="checkbox"/> Breaking strength and Elongation in %                             | EN-ISO 13934-1             | 18 daN  | 22 daN               | daN                                     | daN             |              |
|  |                            | 12,5-40   | 12,5-55              |   |                 |              |
| <input type="checkbox"/> Breaking strength (Grab)  | EN-ISO 13934-2             | 12 daN  | 15 daN               | daN                                     | daN             |              |
| <input type="checkbox"/> Tear strength   | EN-ISO 13937-1             | 0,8 daN   | 1,0 daN              | daN                                     | daN             |              |
| <input type="checkbox"/> Seam slippage: <b>mm at daN</b>                                   | EN-ISO 13936-1             | 4 at 11   | 4 at 12              | 4 at .....                              | 4 at .....      |              |
| <input type="checkbox"/> Seam slippage: <b>daN at mm</b>                                   | EN-ISO 13936-2             | 6 at 3  | 6 at 2               | 6 at .....                              | 6 at .....      |              |
| <input type="checkbox"/> Abrasion resistance (9kPa)  | EN-ISO 12947-2             | 12.000 revs   |                      | revs                                    |                 |              |
| <input type="checkbox"/> Pilling<br>FS= Flat surface<br>RS= Raised surface<br>Kn= Knitwear | EN-ISO 12945-2             | 125 revs  | FS 4, RS 3-4, Kn 3-4 |   |                 |              |
|  |                            | 500 revs  | FS 4, RS 3, Kn 3     |   |                 |              |
|  |                            | 1000 revs   | FS 4, RS 2-3, Kn 2-3 |   |                 |              |
|  |                            | 2000 revs   | FS 4                 |   |                 |              |
| <b>2.4 COLOUR FASTNESS **</b>  | EN-ISO 105 A01-A03         | <b>Change</b>   | <b>Staining</b>      | <b>Change</b>                           | <b>Staining</b> |              |
| <input type="checkbox"/> to washing  | EN-ISO 105 C06, C08, C09   | 4   | 4                    |   |                 |              |
| <input type="checkbox"/> to dry cleaning   | EN-ISO 105 D01             | 4   | -                    |   |                 |              |
| <input type="checkbox"/> to ironing  | EN-ISO 105 X12             | 4   | 4                    |   |                 |              |
| <input type="checkbox"/> to light, weathering  | EN-ISO 105 B02, B04        | 5   | -                    |   |                 |              |
| <input type="checkbox"/> to perspiration, acid   | EN-ISO 105 E04             | 4   | 4                    |   |                 |              |
| <input type="checkbox"/> to perspiration, alkaline   |                            | 4   | 4                    |   |                 |              |
| <input type="checkbox"/> to rubbing, dry   | EN-ISO 105 X12             | -   | 4                    |   |                 |              |
| <input type="checkbox"/> to rubbing, wet   |                            | -   | 3-4                  |   |                 |              |
| <input type="checkbox"/> to water  | EN-ISO 105 E01             | 4   | 4                    |   |                 |              |
| <b>2.5 OTHER CHARACTERISTICS</b>   |                            |   |                      |   |                 |              |
| <input type="checkbox"/> Other   |                            |   |                      |   |                 |              |
| <input type="checkbox"/> Other tests are not considered                                    |                            |   |                      |   |                 |              |

\* For fabrics containing elastane special consultation is recommended.

\* Weft knits: -6% / +2%

\*\* Garments with contrast colours: colour fastness to washing, perspiration and water: staining 4-5. Colour fastness to rubbing of corduroy, denim and heavy shades: dry 3, wet 2.



**SECTION 2.9: CHARACTERISTICS CONCERNING THE FABRIC AND THE GARMENT: LINGERIE**

| CHARACTERISTICS   | STANDARD                 | STANDARD REQUIREMENT EURATEX TCG RECOMMENDATION |                      | SUPPLIER'S VALUES OR TEST RESULTS |                 | Pass Fail |
|---|--------------------------|---|----------------------|-----------------------------------|-----------------|-----------|
| <b>2.1 CARE LABELLING</b>   |                          |   |                      |                                   |                 |           |
| Washing   | EN_ISO 3758              |   |                      |                                   |                 |           |
| Bleaching   |                          |   |                      |                                   |                 |           |
| Drying  |                          |   |                      |                                   |                 |           |
| Ironing   |                          |   |                      |                                   |                 |           |
| Dry cleaning  |                          |   |                      |                                   |                 |           |
| <b>2.2 DIMENSIONAL STABILITY</b>  |                          | <b>Length</b>                                   | <b>Width</b>         | <b>Length</b>                     | <b>Width</b>    |           |
| <input type="checkbox"/> Washing / drying (as indicated by the care label)* | ISO 5077                 | -2,0%   | -2,0%                | %                                 | %               |           |
| <input type="checkbox"/> Dry cleaning                                       | EN-ISO 6330              |   |                      |                                   |                 |           |
|   | EN-ISO 3175              | -1,5%   | -1,5%                | %                                 | %               |           |
| <b>2.3 MECHANICAL AND PHYSICAL PROPERTIES</b>                               |                          | <b>Full fit</b>                                 | <b>Tight fit</b>     |                                   |                 |           |
| <input type="checkbox"/> Breaking strength and Elongation in %              | EN-ISO 13934-1           | 18 daN  | 22 daN               | daN                               | daN             |           |
|   |                          | 12,5 - 40                                       | 12,5 -55             |                                   |                 |           |
| <input type="checkbox"/> Breaking strength (Grab)                           | EN-ISO 13934-2           | 12 daN  | 15 daN               | daN                               | daN             |           |
| <input type="checkbox"/> Tear strength                                      | EN-ISO 13937-1           | 0,8 daN   | 1,0                  | daN                               | daN             |           |
| <input type="checkbox"/> Seam slippage: mm at daN                           | EN-ISO 13936-1           | 4 at 10   | 4 at 12              | 4 at .....                        | 4 at .....      |           |
| <input type="checkbox"/> Seam slippage: daN at mm                           | EN-ISO 13936-2           | 6 at 3  | 6 at 2               | 6 at .....                        | 6 at 2          |           |
| <input type="checkbox"/> Bursting strength                                  | EN-ISO 13938-2           | 200 kPa, (7,3 cm <sup>2</sup> )                 |                      |                                   |                 |           |
| <input type="checkbox"/> Abrasion resistance (9kPa)                         | EN-ISO 12947-2           | 10.000 revs.                                    |                      | revs                              |                 |           |
| <input type="checkbox"/> Pilling  | EN-ISO 12945-2           | 125 revs  | FS 4, RS 3-4, Kn 3-4 |                                   |                 |           |
| <input type="checkbox"/> FS= Flat surface                                   |                          | 500 revs  | FS 4, RS 3, Kn 3     |                                   |                 |           |
| <input type="checkbox"/> RS= Raised surface                                 |                          | 1000 revs                                       | FS 4, RS 2-3, Kn 2-3 |                                   |                 |           |
| <input type="checkbox"/> Kn= Knitwear                                       |                          | 2000 revs                                       | FS 4                 |                                   |                 |           |
| <b>2.4 COLOUR FASTNESS **</b>   | EN-ISO 105 A01-A03       | <b>Change</b>                                   | <b>Staining</b>      | <b>Change</b>                     | <b>Staining</b> |           |
| <input type="checkbox"/> to washing   | EN-ISO 105 C06, C08, C09 | 4   | 4                    |                                   |                 |           |
| <input type="checkbox"/> to dry cleaning                                    | EN-ISO 105 D01           | 4   | -                    |                                   |                 |           |
| <input type="checkbox"/> to ironing   | EN-ISO 105 X12           | 4   | 4                    |                                   |                 |           |
| <input type="checkbox"/> to light, weathering                               | EN-ISO 105 B02, B04      | 4   | -                    |                                   |                 |           |
| <input type="checkbox"/> to perspiration, acid                              | EN-ISO 105 E04           | 4   | 4                    |                                   |                 |           |
| <input type="checkbox"/> to perspiration, alkaline                          |                          | 4   | 4                    |                                   |                 |           |
| <input type="checkbox"/> to rubbing , dry                                   | EN-ISO 105 X12           | -   | 4                    |                                   |                 |           |
| <input type="checkbox"/> to rubbing , wet                                   |                          | -   | 3-4                  |                                   |                 |           |
| <input type="checkbox"/> towater  | EN-ISO 105 E01           | 4   | 4                    |                                   |                 |           |
| <b>2.5 OTHER CHARACTERISTICS</b>  |                          |   |                      |                                   |                 |           |
| <input type="checkbox"/> Other  |                          |   |                      |                                   |                 |           |
| <input type="checkbox"/> Other tests are not considered                     |                          |   |                      |                                   |                 |           |

\* For fabrics containing elastane special consultation is recommended.

\* Weft knits: -6% / +2%

\*\* Garments with contrast colours: colour fastness to washing, perspiration and water: staining 4-5.

**SECTION 2.10: CHARACTERISTICS CONCERNING THE FABRIC AND THE GARMENT: SWIMWEAR**

| CHARACTERISTICS   | STANDARD   | STANDARD REQUIREMENT EURATEX TCG RECOMMENDATION            |                 | SUPPLIER'S VALUES OR TEST RESULTS |                 | Pass Fail |  |
|---|--|--|-----------------|-----------------------------------|-----------------|-----------|--|
| <b>2.1 CARE LABELLING</b>   |  |  |                 |                                   |                 |           |  |
| Washing   | EN-ISO 3758  |  |                 |                                   |                 |           |  |
| Bleaching   |  |  |                 |                                   |                 |           |  |
| Drying  |  |  |                 |                                   |                 |           |  |
| Ironing   |  |  |                 |                                   |                 |           |  |
| Dry cleaning  |  |  |                 |                                   |                 |           |  |
| <b>2.2 DIMENSIONAL STABILITY</b>  |  | <b>Length</b>  | <b>Width</b>    | <b>Length</b>                     | <b>Width</b>    |           |  |
| <input type="checkbox"/> Steaming (pressing machine)                        | DIN 52894 P2   | +/-1,0%  | -2,0%           | %                                 | %               |           |  |
| <input type="checkbox"/> Washing / drying (as indicated by the care label)* | ISO 5077   | -2,0%  | -2,0%           | %                                 | %               |           |  |
| <input type="checkbox"/> Dry cleaning                                       | EN-ISO 6330<br>EN-ISO 3175   | -1,5%  | -1,5%           | %                                 | %               |           |  |
| <b>2.3 MECHANICAL AND PHYSICAL PROPERTIES</b>                               |  |  |                 |                                   |                 |           |  |
| <input type="checkbox"/> Breaking strength and Elongation in %              | EN-ISO 13934-1   | 22 daN<br>12,5 - 40  |                 | daN                               | daN             |           |  |
| <input type="checkbox"/> Breaking strength (Grab)                           | EN-ISO 13934-2   | 15 daN   |                 | daN                               | daN             |           |  |
| <input type="checkbox"/> Tear strength                                      | EN-ISO 13937-1   | 1,0  |                 | daN                               | daN             |           |  |
| <input type="checkbox"/> Seam slippage: <b>mm at daN</b>                    | EN-ISO 13936-1   | 4 at 14  | 4 at 14         | 4 at .....                        | 4 at .....      |           |  |
| <input type="checkbox"/> Seam slippage: <b>daN at mm</b>                    | EN-ISO 13936-2   | 6 at 3   | 6 at 2          | 6 at .....                        | 6 at .....      |           |  |
| <input type="checkbox"/> Bursting strength                                  | EN-ISO 13938-2   | 200 kPa, (7,3 cm <sup>2</sup> )                            |                 |                                   |                 |           |  |
| <input type="checkbox"/> Abrasion resistance (9kPa)                         | EN-ISO 12947-2   | 20.000 revs.   |                 | revs                              |                 |           |  |
| <input type="checkbox"/> Pilling  | EN-ISO 12945-2   | 125 revs: 4<br>500 revs: 4<br>1000 revs: 4<br>2000 revs: 4 |                 |                                   |                 |           |  |
| <b>2.4 COLOUR FASTNESS **</b>   | EN-ISO 105 A01-A03   | <b>Change</b>  | <b>Staining</b> | <b>Change</b>                     | <b>Staining</b> |           |  |
| <input type="checkbox"/> to washing   | EN-ISO 105 C06, C08, C09   | 4  | 4               |                                   |                 |           |  |
| <input type="checkbox"/> to dry cleaning                                    | EN-ISO 105 D01   | 4  | -               |                                   |                 |           |  |
| <input type="checkbox"/> to ironing   | ISO 105 X12  | 4  | 4               |                                   |                 |           |  |
| <input type="checkbox"/> to light, weathering                               | EN-ISO 105 B02, B04  | 5  | -               |                                   |                 |           |  |
| <input type="checkbox"/> to perspiration, acid                              | EN-ISO 105 E04   | 4  | 4               |                                   |                 |           |  |
| <input type="checkbox"/> to perspiration, alkaline                          |  | 4  | 4               |                                   |                 |           |  |
| <input type="checkbox"/> to sea water                                       | EN-ISO 105 E02   | 4  | 4               |                                   |                 |           |  |
| <input type="checkbox"/> to chlorinated water                               | EN-ISO 105 E03   | 4  | -               |                                   |                 |           |  |
| <input type="checkbox"/> to rubbing , dry                                   | EN-ISO 105 X12   | -  | 4               |                                   |                 |           |  |
| <input type="checkbox"/> to rubbing , wet                                   |  | -  | 3-4             |                                   |                 |           |  |
| <input type="checkbox"/> to water   | EN-ISO 105 E01   | 4  | 4               |                                   |                 |           |  |
| <b>2.5 OTHER CHARACTERISTICS</b>  |  |  |                 |                                   |                 |           |  |
| <input type="checkbox"/> Other  | Material must not be transparent.<br>UV light must not deteriorate material. |  |                 |                                   |                 |           |  |
| <input type="checkbox"/> Other tests are not considered                     |  |  |                 |                                   |                 |           |  |

\* For fabrics containing elastane special consultation is recommended.

\* Weft knits: -6% / +2%

\*\* Garments with contrast colours: colour fastness to washing, perspiration and water: staining 4-5.

**SECTION 2.11: CHARACTERISTICS CONCERNING THE FABRIC AND THE GARMENT: LINING**

| CHARACTERISTICS  | STANDARD                   | STANDARD REQUIREMENT EURATEX TCG RECOMMENDATION |                      | SUPPLIER'S VALUES OR TEST RESULTS |                 | Pass Fail |
|--|----------------------------|---|----------------------|-----------------------------------|-----------------|-----------|
| <b>2.1 CARE LABELLING</b>  |                            |   |                      |                                   |                 |           |
| Washing  | EN-ISO 3758                |   |                      |                                   |                 |           |
| Bleaching  |                            |   |                      |                                   |                 |           |
| Drying   |                            |   |                      |                                   |                 |           |
| Ironing  |                            |   |                      |                                   |                 |           |
| Dry cleaning   |                            |   |                      |                                   |                 |           |
| <b>2.2 DIMENSIONAL STABILITY</b>   |                            | <b>Length</b>                                   | <b>Width</b>         | <b>Length</b>                     | <b>Width</b>    |           |
| <input type="checkbox"/> Steaming (pressing machine)                                       | DIN 52894 P2               | +/-1,0%   | -2,0%                | %                                 | %               |           |
| <input type="checkbox"/> Fusing (fusing press)   | DIN 54311                  | -1,5%   | -1,5%                | %                                 | %               |           |
| <input type="checkbox"/> Washing / drying (as indicated by the care label)*                | ISO 5077                   | -3,0%   | -3,0%                | %                                 | %               |           |
| <input type="checkbox"/> Dry cleaning  | EN-ISO 6330<br>EN-ISO 3175 | -1,5%   | -1,5%                | %                                 | %               |           |
| <b>2.3 MECHANICAL AND PHYSICAL PROPERTIES</b>  |                            | <b>Full fit</b>                                 | <b>Tight fit</b>     |                                   |                 |           |
| <input type="checkbox"/> Breaking strength and Elongation in %                             | EN-ISO 13934-1             | 18 daN<br>7,5-32,5                              | 22 daN<br>7,5-32,5   | daN                               | daN             |           |
| <input type="checkbox"/> Breaking strength (Grab)  | EN-ISO 13934-2             | 12 daN  | 15 daN               | daN                               | daN             |           |
| <input type="checkbox"/> Tear strength   | EN-ISO 13937-1             | 0,8 daN   | 1,0 daN              | daN                               | daN             |           |
| <input type="checkbox"/> Seam slippage: <b>mm at daN</b>                                   | EN-ISO 13936-1             | 4 at 10   | 4 at 12              | 4 at .....                        | 4 at .....      |           |
| <input type="checkbox"/> Seam slippage: <b>daN at mm</b>                                   | EN-ISO 13936-2             | 6 at 3  | 6 at 3               | 6 at .....                        | 6 at .....      |           |
| <input type="checkbox"/> Bursting strength   | EN-ISO 13938-2             | 200 kPa, (7,3 cm <sup>2</sup> )                 |                      |                                   |                 |           |
| <input type="checkbox"/> Abrasion resistance (9kPa)  | EN-ISO 12947-2             | 10.000 revs                                     |                      |                                   |                 |           |
| <input type="checkbox"/> Pilling<br>FS= Flat surface<br>RS= Raised surface<br>Kn= Knitwear | EN-ISO 12945-2             | 125 revs  | FS 4, RS 3-4, Kn 3-4 |                                   |                 |           |
|  |                            | 500 revs  | FS 4, RS 3, Kn 3     |                                   |                 |           |
|  |                            | 1000 revs                                       | FS 4, RS 2-3, Kn 2-3 |                                   |                 |           |
|  |                            | 2000 revs                                       | FS 4                 |                                   |                 |           |
| <b>2.4 COLOUR FASTNESS **</b>  | EN-ISO 105 A01-A03         | <b>Change</b>                                   | <b>Staining</b>      | <b>Change</b>                     | <b>Staining</b> |           |
| <input type="checkbox"/> to washing  | EN-ISO 105 C06, C08, C09   | 3-4   | 3-4                  |                                   |                 |           |
| <input type="checkbox"/> to dry cleaning   | ISO 105 D01                | 4   | -                    |                                   |                 |           |
| <input type="checkbox"/> to ironing  | ISO 105 X12                | 4   | 4                    |                                   |                 |           |
| <input type="checkbox"/> to light, weathering  | EN-ISO 105 B02, B04        | 4   | -                    |                                   |                 |           |
| <input type="checkbox"/> to perspiration, acid   | EN-ISO 105 E04             | 3-4   | 3-4                  |                                   |                 |           |
| <input type="checkbox"/> to perspiration, alkaline   |                            | 3-4   | 3-4                  |                                   |                 |           |
| <input type="checkbox"/> to rubbing, dry   | EN-ISO 105 X12             | -   | 4                    |                                   |                 |           |
| <input type="checkbox"/> to rubbing, wet   |                            | -   | 3-4                  |                                   |                 |           |
| <input type="checkbox"/> to water  | EN-ISO 105 E01             | 4   | 4                    |                                   |                 |           |
| <b>2.5 OTHER CHARACTERISTICS</b>   |                            |   |                      |                                   |                 |           |
| <input type="checkbox"/> Other   |                            |   |                      |                                   |                 |           |
| <input type="checkbox"/> Other tests are not considered                                    |                            |   |                      |                                   |                 |           |

\* For fabrics containing elastane special consultation is recommended.

\*\* Garments with contrast colours: colour fastness to washing, perspiration and water: staining 4-5.

## VI. SHORT EXPLANATION OF TEST METHODS

### CONTENTS OF THIS PART

|           |  |  |    |
|-----------|--|--|----|
| <b>VI</b> | <b>Short explanation of the test methods</b> | <b>76-86</b>   |    |
|           | CONTENTS OF THIS PART                        | 76   |    |
| 1.        | ISO 5077 & 6330                              | Dimensional stability to machine washing and tumble drying.    | 77 |
| 2.        | ISO 3175                                     | Dimensional stability to commercial dry-cleaning.              | 77 |
| 3.        | ISO 13938-2                                  | Bursting strength, bursting distension.                        | 77 |
| 4.        | ISO 13934-1                                  | Tensile strength – strip.                                      | 78 |
| 5.        | ISO 13934-2                                  | Tensile strength – grab.                                       | 78 |
| 6.        | ISO 13937-1                                  | Tear strength.   | 78 |
| 7.        | EN 13936-1                                   | Seam slippage: Fixed seam opening method                       | 79 |
| 8.        | EN 13936-2                                   | Seam slippage: Fixed load method                               | 79 |
| 8.        | EN 12947-2                                   | Abrasion resistance.   | 80 |
| 9.        | EN 2313                                      | Crease tendency / angle of recovery.                           | 80 |
| 10.       | ISO 9867                                     | Crease tendency / wrinkle recovery.                            | 81 |
| 11.       | EN-ISO 12945-2                               | Resistance to pilling.   | 81 |
| 12.       | ASTM D 3939-93                               | Resistance to snagging.  | 81 |
| 13.       | ISO 105 C06/08/09                            | Colour fastness to washing.                                    | 82 |
| 14.       | ISO 105 D01                                  | Colour fastness to dry cleaning.                               | 82 |
|           | ISO 105 D02                                  | Colour fastness to rubbing organic solvents.                   | 82 |
| 15.       | ISO 105 X11                                  | Colour fastness to hot pressing-ironing                        | 83 |
| 16.       | ISO 105 B02/04                               | Colour fastness to artificial light and artificial weathering. | 83 |
| 17.       | ISO 105 X12                                  | Colour fastness to rubbing.                                    | 84 |
| 18.       | ISO 105 E01                                  | Colour fastness to water.                                      | 84 |
|           | ISO 105 E02                                  | Colour fastness to sea water.                                  | 84 |
|           | ISO 105 E04                                  | Colour fastness to perspiration.                               | 84 |
| 19.       | ISO 105 E07                                  | Colour fastness to spotting water.                             | 84 |
| 20.       | ISO 105 E03                                  | Colour fastness to chlorinated water.                          | 85 |
| 21.       | ISO 3758                                     | Care labelling codes using symbols.                            | 85 |
| 22.       | ISO 4920                                     | Water-repellency   | 85 |
| 23.       | ISO 811 + EN 343                             | Water-proofness  | 86 |
| 24.       | EN-ISO 9237                                  | Air permeability   | 86 |
| 25.       | EN 12447                                     | Resistance to hydrolysis                                       | 86 |

## **1. ISO 5077 & ISO 6330**

### **DIMENSIONAL STABILITY TO MACHINE WASHING AND TUMBLE DRYING**

#### **SCOPE**

This method is intended to determine the dimensional stability of textiles to combinations of domestic washing and drying procedures. The method is applicable to all washable fabrics and garments.

#### **PRINCIPLE**

A specimen fabric or garment, is washed in an automatic washing machine and dried according to specified procedures. Any change in dimensions is determined.

## **2. ISO 3175**

### **DIMENSIONAL STABILITY TO COMMERCIAL DRY-CLEANING**

#### **SCOPE**

This method is intended to determine the dimensional stability of textiles to commercial dry-cleaning. The method is applicable to all dry-cleanable fabrics and garments.

#### **PRINCIPLE**

A specimen fabric or garment is subjected to a commercial dry cleaning process and any change in dimensions is determined.

## **3. ISO 13938-2**

### **DETERMINATION OF BURSTING STRENGTH AND BURSTING DISTENSION, DIAPHRAGM METHOD**

#### **SCOPE**

This method is intended to determine the bursting strength and bursting distension of fabrics. The method is applicable to all fabrics apart from those impregnated or coated with sizings or stiffening materials.

#### **PRINCIPLE**

The area of the fabric to be tested is clamped over an elastic diaphragm by means of a flat annular clamping ring, and an increasing air pressure is applied to the underside of the specimen until the specimen bursts. The surface of the orifice is preferably 7,3 cm<sup>2</sup>.

#### **4. ISO 13934-1**

##### **TENSILE STRENGTH OF FABRIC - STRIP METHOD**

###### **SCOPE**

This method is intended to determine the tensile strength of a sample fabric specimen using an autographic tensile tester.

###### **PRINCIPLE**

With the use of an autographic tensile tester, a 50 mm wide specimen is extended until it breaks in order to measure its breaking load and elongation.

#### **5. ISO 13934-2**

##### **TENSILE STRENGTH OF FABRIC - GRAB METHOD**

###### **SCOPE**

This method is intended to determine the tensile strength of a fabric specimen using an autographic tensile tester.

###### **PRINCIPLE**

With the use of an autographic tensile tester, a 100 mm wide specimen is extended until it breaks in order to measure its breaking load.

#### **6. ISO 13937-1**

##### **TEAR STRENGTH - FALLING PENDULUM METHOD**

###### **SCOPE**

This method is intended to determine the tear strength of fabrics. The method is applicable to all types of woven fabric in which a tear will proceed from an initial cut in a direction parallel to the warp or weft threads.

###### **PRINCIPLE**

Specimens are torn by a falling pendulum and the work expended is determined from the difference between the height to which the pendulum rises after completing the tear and the height to which it rises in the absence of the specimen.

## **7. EN 13936-1**

### **SEAM SLIPPAGE - FIXED SEAM OPENING METHOD**

#### **SCOPE**

This method is intended to determine the tendency of woven apparel fabrics to slip at stitched seams. Tests are made until a pre determined fixed seam opening (to be agreed between parties) is reached. Then the necessary force to achieve this opening is registered. In this document a seam opening of 4 mm is recommended. The method is applicable to all types of woven apparel fabrics except stretch fabrics.

#### **PRINCIPLE**

A 100 mm wide strip of fabric is folded and stitched across its width. The strip is cut at the fold, and then extended at right angles to the seam using grab test jaws, and the load required to cause the specified seam opening is determined.

## **8. EN 13936-2**

### **SEAM SLIPPAGE - FIXED LOAD METHOD**

#### **SCOPE**

This method is intended to determine the tendency of woven apparel fabrics to slip at stitched seams. Tests are made until a pre determined fixed load (to be agreed between parties; in this document 6 daN and 12 daN) is reached. Then the opening is measured. In this document seam openings of 2 mm, 3 mm and 4 mm are recommended. The method is applicable to all types of woven apparel fabrics including those containing elastomeric yarn .

#### **PRINCIPLE**

A 100 mm wide strip of fabric is folded and stitched across its width. The strip is cut at the fold and then extended at right angles to the seam using grab test jaws and the seam opening at the specified load is determined.

## **9. EN 12947-2**

### **ABRASION RESISTANCE - MARTINDALE**

#### **SCOPE**

This method is intended to determine the resistance of a fabric to abrasion. The harshness of the abrasion can be varied by using different cycles and contact pressures. The method is applicable to all textile fabrics.

#### **PRINCIPLE**

Specimens are abraded against a standard abradant fabric under a constant contact force of 9kPa or 12kPa depending on the end-use of the fabric. The relative movement between the abradant and specimen is a complex cyclic pattern (a lissajous figure) which produces rubbing in all directions. The test is stopped after a prescribed number of cycles and the specimen is assessed subjectively to determine whether breakdown has occurred.

## **10. EN 2313**

### **DETERMINATION OF RECOVERY FROM CREASING OF TEXTILE FABRICS BY MEASURING THE ANGLE OF RECOVERY**

#### **SCOPE**

This method is intended to determine the angle of recovery of fabrics from creasing in either the standard atmosphere for testing or one of higher humidity and temperature. The method is applicable to all types of fabrics but some types of fabrics may tend to curl resulting in an unacceptable precision in making measurements.

#### **PRINCIPLE**

A rectangular specimen of prescribed dimensions is folded by a suitable device and maintained in this state for a specified time under a specified load. The creasing load is removed, the specimen allowed to recover for a specified time, and the recovery angle is then measured.



## **11. ISO 9867**

### **EVALUATION OF THE WRINKLE RECOVERY OF FABRICS - APPEARANCE METHOD.**

#### **SCOPE**

This method is intended to evaluate the appearance of textile fabrics after induced wrinkling. It is applicable to fabrics made from any fibre or combination of fibres.

#### **PRINCIPLE**

A test specimen is wrinkled under specified atmospheric conditions in a wrinkling device under a predetermined load for a prescribed period of time. The specimen is reconditioned in a standard atmosphere and evaluated for appearance by comparison with three-dimensional wrinkle recovery replicas.

## **12. EN-ISO 12945-2**

### **RESISTANCE TO PILLING**

#### **SCOPE**

This method is intended to determine the resistance to pilling of apparel fabrics. The method is applicable to woven and knitted fabrics.

#### **PRINCIPLE**

Specimens of fabrics are abraded against themselves under a constant pressure. The relative movement between the specimens is a complex cyclic pattern (a lissajous figure) which produces rubbing in all directions. The test is stopped after a prescribed number of cycles and the specimens are assessed using standard definitions that describe the degree of pilling.

## **13. ASTM D 3939 - 93**

### **RESISTANCE TO SNAGGING**

#### **SCOPE**

This test method determines the snagging resistance of a fabric.

#### **PRINCIPLE**

Fabric specimens in tubular form are placed one at a time on a rotating cylinder. A mace (spiked ball) is allowed to bounce randomly against each rotating specimen. As the mace bounces over each specimen, snags could occur to a degree affected by a variety of fabric factors.

## **14. ISO 105 C06 / C08 / C09**

### **COLOUR FASTNESS TO WASHING**

#### **SCOPE**

This series of methods is intended to determine the fastness to washing of coloured textiles covering a range of washing procedures from mild to severe. The method is applicable to all washable textiles.

#### **PRINCIPLE**

A specimen of the textile in contact with a multifibre fabric or two different fabrics is mechanically agitated under specified conditions of time and temperature in a detergent solution, then rinsed and dried. The change in colour of the specimen and the staining of the multifibre fabric or two different fabrics are assessed with standard grey scales.

## **15. ISO 105 D01, D02**

### **COLOUR FASTNESS TO DRY CLEANING AND TO RUBBING ORGANIC SOLVENTS**

#### **SCOPE**

This method is intended to determine the resistance of the colour of textiles to dry cleaning and to rubbing organic solvents. The method is applicable to all kinds of textiles in all forms.

#### **PRINCIPLE**

A specimen of the textile packed in a cotton fabric bag together with non-corrodible steel discs is agitated in perchloroethylene, then squeezed or centrifuged and dried in hot air. The change in colour of the specimen is assessed with the grey scale for assessing change in colour. At the conclusion of the test, the coloration of the solvent is assessed by comparing the filtered solvent with unused solvent by transmitted light, by means of the grey scale for assessing staining.

## **16. ISO 105 X11**

### **COLOUR FASTNESS TO HOT PRESSING - IRONING**

#### **SCOPE**

This method is intended to determine the resistance of the colour of textiles to ironing and to processing on hot rollers. The method is applicable to all kinds of textiles in all forms.

#### **PRINCIPLE**

Dry pressing. A dry specimen is pressed with a heating device at a specified temperature and pressure for a specified time.

Damp pressing. A dry specimen is covered with a wet cotton adjacent fabric and pressed with a heating device at a specified temperature and pressure for a specified time.

Wet pressing. The upper surface of a wet specimen is covered with a wet cotton adjacent fabric and pressed with a heating device at a specified temperature and pressure for a specified time.

The change in colour of the specimen and the staining of the adjacent fabric are assessed with grey scales immediately and after a period of exposure to air.

## **17. ISO 105 B02 / B04**

### **COLOUR FASTNESS TO ARTIFICIAL LIGHT AND ARTIFICIAL WEATHERING: XENON ARC FADING LAMP TEST**

This method is intended to determine the resistance of the colour of textiles to the action of an artificial light source representative of natural daylight and / or artificial weathering. The method is applicable to all types of textiles in all forms.

#### **PRINCIPLE**

The specimen is exposed to artificial light under prescribed conditions along with Blue Wool References. The colour fastness is assessed by comparing the change in colour of the specimen with that of the Blue Wool Reference used.

## **18. ISO 105 X12**

### **COLOUR FASTNESS TO RUBBING (CROCKING)**

#### **SCOPE**

This method is intended to determine the resistance of the colour of textiles to rubbing off and staining other materials. Two tests are made, one with a dry rubbing cloth and one with a wet rubbing cloth. The method is applicable to fabrics and yarns.

#### **PRINCIPLE**

Specimens of the textile are rubbed with dry undyed cotton cloth and with wet undyed cotton cloth. The staining of the rubbing cloths is assessed with grey scales.

## **19. ISO 105 E01, E02, E04**

### **COLOUR FASTNESS TO WATER, SEA WATER, PERSPIRATION**

#### **SCOPE**

These methods are intended to determine the likelihood of colour bleeding from materials due to the action of respectively water, sea water and perspiration. The methods are applicable to all types of textile materials in all forms.

#### **PRINCIPLE**

A specimen of the material is placed in contact with a standard multifibre fabric or two different fabrics. The assembly is then immersed in either distilled water, sodium chloride solution or acid and alkali solutions of histidine. The solution is drained off and the assembly is sandwiched between acrylic plates and then placed in an oven at 37°C for 4 hours. The specimen and the adjacent fabric are dried separately. The change in colour of the specimen and the staining of the adjacent fabric are assessed with grey scales.

## **20. ISO 105 E 07**

### **COLOUR FASTNESS TO SPOTTING: WATER**

#### **SCOPE**

This method is intended to determine the resistance of the colour of textiles to the action of water drops.

#### **PRINCIPLE**

Drops of water are worked into the specimen with a glass rod, and the change in colour of the textile is assessed with the grey scale for testing colour change after 2 minutes and after drying.

## **21. ISO 105 E03**

### **COLOUR FASTNESS TO CHLORINATED WATER**

#### **SCOPE**

This method is intended to determine the resistance of the colour of textiles to the action of active chlorine in concentrations such as are used to disinfect swimming-bath water.

#### **PRINCIPLE**

A specimen of the textile is treated with a weak chlorine solution of a given concentration and dried. The change in colour of the specimen is assessed with a grey scale. Three alternative test conditions are specified. A solution of 50 mg/l active chlorine is recommended.

## **22. ISO 3758**

### **CARE LABELLING CODES USING SYMBOLS**

#### **SCOPE**

This International Standard establishes a system of graphic symbols, intended for use in the marking of textile articles, providing information to prevent irreversible damage to the article during the textile care process.

It specifies the use of these symbols in care labelling.

The following domestic treatments are covered: washing, bleaching, ironing, and drying after washing. Professional textile care treatments in dry and wet cleaning, but excluding industrial laundering, are also covered. However, it is recognized that information imparted by the four domestic symbols will also be of assistance to the professional cleaner and launderer. This International Standard applies to all textile articles in the form in which they are supplied to the end user.

## **23. ISO 4920**

### **WATER-REPELLENCY**

#### **SCOPE**

This method is intended to evaluate the water-repellency properties of fabrics. A specified volume of demineralised water is sprayed on a test specimen which is mounted in a ring and placed at an angle of 45 °. The water repellent property of the fabric is assessed by giving it a “spray rating” which is determined by comparing the appearance of the specimen with standard photographs.

## **24. ISO 811 and EN 343**

### **WATER-PROOFNESS**

#### **SCOPE**

Test method ISO 811 specifies a hydrostatic pressure method for determining the resistance of fabrics to penetration by water.

Test method EN 343 specifies requirements and test methods applicable to materials and seams of (protective) clothing against the influence of precipitation e.g. rain and snowflakes.

## **25. EN ISO 9237**

### **AIR PERMEABILITY**

#### **SCOPE**

This method is intended to determine the rate of flow of air passing perpendicularly through a given area of fabric. The rate of flow is measured at a given pressure difference across the fabric test area.

## **26. EN 12447**

### **RESISTANCE TO HYDROLYSIS**

#### **SCOPE**

This method specifies a procedure for determining the resistance of fabrics to hydrolysis by exposing specimen to water at an elevated temperature. Changes in properties resulting from such exposure are evaluated.